

**RICOH**

# Aficio™ AP3200

**Setup Guide**

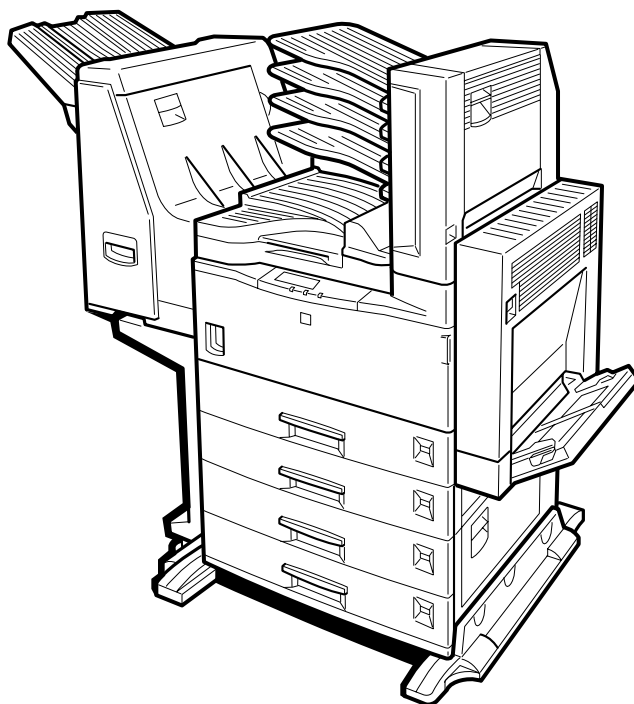

Read this manual carefully before you use this product and keep it handy for future reference.

For safety, please follow the instructions in this manual.

## Introduction

This manual contains detailed instructions on the operation and maintenance of this machine. To get maximum versatility from this machine all operators should carefully read and follow the instructions in this manual. Please keep this manual in a handy place near the machine.

Please read the Safety Information before using this machine. It contains important information related to USER SAFETY and PREVENTING EQUIPMENT PROBLEMS.

### Note

The actual names of the following applications do not appear on the following pages. Confirm which applications you will be using before reading this manual.

Descriptions in this manual	Application
PRINTER MANAGER FOR ADMINISTRATOR	Aficio Manager for Admin
PRINTER MANAGER FOR CLIENT	Aficio Manager for Client

### Software Version Conventions Used in This Manual

- NetWare 3.x refers to NetWare 3.12 and 3.2.
- NetWare 4.x refers to NetWare 4.1, 4.11 and IntranetWare.

### Power Source

220-240 V, 50/60 Hz, 4.5 A or more

Please be sure to connect the power cord to a power source as above.

### Operator Safety:

This machine is considered a class 1 laser device, safe for office/ EDP use. The machine contains 5-milliwatt, 760 - 800 nanometer wavelength, GaAIAs laser diode. Direct (or indirect reflected) eye contact with the laser beam might cause serious eye damage. Safety precautions and interlock mechanisms have been designed to prevent any possible laser beam exposure to the operator.

The following label is attached on the back side of the machine.

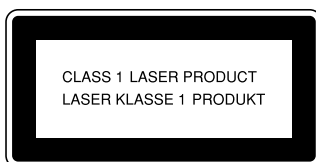

### Laser Safety:

The optical housing unit can only be repaired in a factory or at a location with the requisite equipment. The laser subsystem is replaceable in the field by a qualified Customer Engineer. The laser chassis is not repairable in the field. Customer engineers are therefore directed to return all chassis and laser subsystems to the factory or service depot when replacement or the optical subsystem is required.

### Important

Parts of this manual are subject to change without prior notice. In no event will the company be liable for direct, indirect, special, incidental, or consequential damages as a result of handling or operating the machine.

### Caution:

Use of controls or adjustment or performance of procedures other than those specified in this manual might result in hazardous radiation exposure.

Do not attempt any maintenance or troubleshooting other than that mentioned in this manual. This machine contains a laser beam generator and direct exposure to laser beams can cause permanent eye damage.

Two kinds of size notation are employed in this manual. With this machine refer to the metric version.

Ricoh shall not be responsible for any damage or expense that might result from the use of parts other than genuine Ricoh parts in your Ricoh office product.

For good copy quality, Ricoh recommends that you use genuine Ricoh toner.

**Trademarks**

Microsoft<sup>®</sup>, Windows<sup>®</sup>, and Windows NT<sup>®</sup> are registered trademarks of Microsoft Corporation in the United States and/or other countries.

Adobe<sup>®</sup>, PostScript<sup>®</sup> and Acrobat<sup>®</sup> and PageMaker<sup>®</sup> are registered trademarks of Adobe System Incorporated.

PCL<sup>®</sup> is a registered trademark of Hewlett-Packard Company.

AppleTalk, Apple, Macintosh, TrueType, LaserWriter are registered trademarks of Apple Computer, Incorporated.

IPS-PRINT<sup>™</sup> Printer Language Emulation<sup>®</sup> Copyright 1999-2000, XIONICS DOCUMENT TECHNOLOGIES, INC., All Rights Reserved.

Ethernet<sup>®</sup> is a registered trademark of Xerox Corporation.

PowerPC<sup>®</sup> is a registered trademark of International Business Machines Corporation.

Novell and NetWare are registered trademarks of Novell, Inc.

Other product names used herein are for identification purposes only and might be trademarks of their respective companies. We disclaim any and all rights involved with those marks.

**Notes:**

Some illustrations might be slightly different from your machine.

Certain options might not be available in some countries. For details, please contact your local dealer.

**Note**

The proper names of the Windows operating systems are as follows:

- Microsoft<sup>®</sup> Windows<sup>®</sup> 95 operating system
- Microsoft<sup>®</sup> Windows<sup>®</sup> 98 operating system
- Microsoft<sup>®</sup> Windows<sup>®</sup> Millennium Edition (Windows Me)
- Microsoft<sup>®</sup> Windows<sup>®</sup> 2000 Professional
- Microsoft<sup>®</sup> Windows<sup>®</sup> 2000 Server
- Microsoft<sup>®</sup> Windows NT<sup>®</sup> Server operating system Version 4.0
- Microsoft<sup>®</sup> Windows NT<sup>®</sup> Workstation operating system Version 4.0

# Safety Information

When using your equipment, the following safety precautions should always be followed.

---

## Safety During Operation

---

In this manual, the following important symbols are used:

- |  |
|--|
| <p><b>⚠ WARNING:</b><br/><i>Indicates a potentially hazardous situation which, if instructions are not followed, could result in death or serious injury.</i></p> <p><b>⚠ CAUTION:</b><br/><i>Indicates a potentially hazardous situation which, if instructions are not followed, may result in minor or moderate injury or damage to property.</i></p> |
|--|

---

**⚠ WARNING:**

---

- ***Connect the power cord directly into a wall outlet and never use an extension cord.***
- ***Confirm that the wall outlet is near the machine and freely accessible, so that in event of an emergency, it can be unplugged easily.***
- ***Disconnect the power plug (by pulling the plug, not the cable) if the power cable or plug becomes frayed or damaged.***
- ***To avoid hazardous electric shock or laser radiation exposure, do not remove any covers or screws other than those specified in this manual.***
- ***Turn off the power and disconnect the power plug (by pulling the plug, not the cable) if any of the following conditions exist:***
  - ***You spill something into the equipment.***
  - ***You suspect that your equipment needs service or repair.***
  - ***Your equipment's cover has been damaged.***
- ***Do not incinerate spilled toner or used toner. Toner dust is flammable and might ignite when exposed to an open flame.***
- ***Disposal should take place at an authorized dealer or appropriate collection site.***
- ***If you dispose of the used toner containers yourself, dispose of them according to local regulations.***

---

**⚠ CAUTION:**

---

- *Protect the equipment from dampness or wet weather, such as rain, snow, and so on.*
- *Unplug the power cord from the wall outlet before you move the equipment. While moving the equipment, you should take care that the power cord will not be damaged under the equipment.*
- *When you disconnect the power plug from the wall outlet, always pull the plug (not the cable).*
- *Do not allow paper clips, staples, or other small metallic objects to fall inside the equipment.*
- *Do not eat or swallow toner.*
- *Keep toner (used or unused) and toner cartridge out of reach of children.*
- *For environmental reasons, do not dispose of the equipment or expended supplies at a household waste collection point. Disposal should take place at an authorized dealer or an appropriate collection site.*
- *Our products are engineered to meet the highest standards of quality and functionality. When purchasing expendable supplies, we recommend using only those specified by an authorized dealer.*
- *The inside of the machine becomes very hot. Do not touch the parts with a label indicating a “hot surface”. Touching a “hot surface” could result in a burn injury. (⚠: means “hot surface”).*

# ENERGY STAR Program

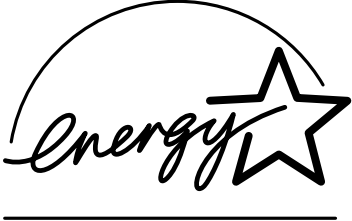
<p>ENERGY STAR®</p> 	<p>As an ENERGY STAR Partner, we have determined that this machine model meets the ENERGY STAR Guidelines for energy efficiency.</p>
---	--

The ENERGY STAR Guidelines intend to establish an international energy-saving system for developing and introducing energy-efficient office equipment to deal with environmental issues, such as global warming.

When a product meets the ENERGY STAR Guidelines for energy efficiency, the Partner shall place the ENERGY STAR logo onto the machine model.

This product was designed to reduce the environmental impact associated with office equipment by means of energy-saving features, such as Low-power mode.

❖ **Low-power mode (Energy Saver mode)**

This printer automatically lowers its power consumption 30 minutes after the last operation has been completed. To exit Low-power (Energy Saver) mode, press any key on the operation panel. For how to configure Energy Saver mode, see "Using the Operation Panel" in the Printer Reference included as a PDF file on the CD-ROM.

❖ **Specifications**

Energy Saver mode	Power Consumption	20 W or less
	Default Time	30 minutes
	Recovery Time	45 seconds or less

.....

 **Recycled Paper**

In accordance with the ENERGY STAR Program, we recommend use of recycled paper which is environment friendly. Please contact your sales representative for recommended paper.

.....

# Manuals for This Printer

There are five manuals that separately describe the procedures for the installation of a printer and for the operation and maintenance of the printer and its optional equipment.

To enhance safe and efficient operation of the printer, all users should read and follow the instructions contained in the following manuals.

## ❖ **Setup Guide**

Describes the procedures and provides necessary information about installing and setting up the printer and its options (this manual). This guide is provided as a printed manual, and also as a PDF file on the CD-ROM labeled "Printer Drivers and Utilities".

## ❖ **Printer Reference**

Describes the procedures and provides necessary information about using the printer and its options. The manual is included as a PDF file on the CD-ROM labeled "Printer Drivers and Utilities".

## ❖ **PostScript 3 Operating Instructions Supplement**

Describes the menus and features you can set using the PostScript printer driver. The manual is included as a PDF file on the CD-ROM labeled "Printer Drivers and Utilities".

## ❖ **Network Interface Board Operating Instructions**

Describes the procedures and provides necessary information about setting up and using the printer in a network environment. The manual is included as a PDF file on the CD-ROM labeled "Printer Drivers and Utilities".

## ❖ **UNIX Supplement**

Provides information about setting up and using the printer in a UNIX environment. This manual is included as a PDF file on the CD-ROM labeled "Printer Drivers and Utilities".



# How to Read This Manual

---

## Symbols

---

In this manual, the following symbols are used:

 **WARNING:**

This symbol indicates a potentially hazardous situation which, if instructions are not followed, could result in death or serious injury.

 **CAUTION:**

This symbol indicates a potentially hazardous situation which, if instructions are not followed, may result in minor or moderate injury or damage to property.

\* The statements above are notes for your safety.

 **Important**

If this instruction is not followed, paper might be misfed, originals might be damaged, or data might be lost. Be sure to read this.

 **Preparation**

This symbol indicates the prior knowledge or preparations required before operating.

 **Note**

This symbol indicates precautions for operation, or actions to take after misoperation.

 **Limitation**

This symbol indicates numerical limits, functions that cannot be used together, or conditions in which a particular function cannot be used.

 **Reference**

This symbol indicates a reference.

[    ]

Keys that appear on the machine's panel display.

Keys and buttons that appear on the computer's display.

[    ]

Keys built into the machine's operation panel.

Keys on the computer's keyboard.

# TABLE OF CONTENTS

## 1. Getting Started

---

<b>Printer Features</b> .....	<b>1</b>
Printer Drivers for This Printer.....	3
<b>Software and Utilities Included on the CD-ROM</b> .....	<b>4</b>
<b>Guide to the Printer</b> .....	<b>5</b>
Exterior: Front View.....	5
Exterior: Rear View.....	6
Interior.....	7
Operation Panel.....	8
Keys.....	9
Guides.....	10

## 2. Setting Up the Printer

---

<b>Unpacking the Printer and Checking the Contents of the Box</b> .....	<b>11</b>
<b>Where to Put the Printer</b> .....	<b>13</b>
<b>Installing Options</b> .....	<b>16</b>
Available Options.....	18
Installing PS440/PS420 (Paper Feed Unit).....	20
Installing Interchange Unit Type 280.....	24
Installing AD380 (Duplex Unit).....	26
Installing Bypass Tray Type 270.....	30
Installing Bridge Unit Type 320.....	33
Installing SR510 (500-sheet finisher).....	35
Installing CS370 (Mailbox).....	37
Installing Memory Unit TypeB.....	39
Installing Printer Hard Disk Type 185.....	40
<b>Installing the Toner Bottle</b> .....	<b>42</b>
<b>Loading Paper</b> .....	<b>44</b>
Loading Paper in the Paper Tray.....	44
Loading Paper in PS420 (Paper Feed Unit).....	47
Loading Paper in Bypass Tray Type 270.....	48
<b>Connecting the Power Cord</b> .....	<b>51</b>
<b>Selecting the Panel Display Language</b> .....	<b>52</b>
<b>Printing a Configuration Page</b> .....	<b>53</b>
<b>Interpreting a Configuration Page</b> .....	<b>54</b>
<b>Connecting the Printer</b> .....	<b>56</b>
Requirements.....	56
Connecting the Printer to the Network.....	57
Connecting the Printer to the Host Using a Parallel Cable.....	60

### 3. Configuring the Printer for the Network

---

Configuring the Printer for the Network with the Operation Panel..... 61

### 4. Installing the Printer Driver and Software

---

<b>Installation Method</b> .....	<b>67</b>
<b>Installing by Auto Run</b> .....	<b>69</b>
<b>Installing the PCL 6/5e Printer Driver</b> .....	<b>70</b>
Windows 95/98/Me - Installing the PCL 6/5e Printer Driver .....	70
Windows 2000 - Installing the PCL 6/5e Printer Driver .....	70
Windows NT 4.0 - Installing the PCL 6/5e Printer Driver .....	71
<b>Installing the PostScript Printer Driver</b> .....	<b>72</b>
Windows 95/98/Me - Installing the PostScript Printer Driver.....	72
Windows 2000 - Installing the PostScript Printer Driver.....	74
Windows NT 4.0 - Installing the PostScript Printer Driver.....	76
<b>Using Adobe PageMaker Version 6.0 or 6.5</b> .....	<b>79</b>
<b>Macintosh</b> .....	<b>80</b>
Macintosh - Installing the PostScript Printer Driver .....	80
Setting Up the PPD File .....	81
Setting Up Options .....	81
<b>INDEX</b> .....	<b>82</b>



# 1. Getting Started

## Printer Features

This printer is designed especially for office workgroups. It can be used in network environments and allows you to manage documents efficiently.

### ❖ High Productivity

This printer comes with a 32 pages per minute (ppm) engine and offers a variety of paper handling options to handle documents efficiently. The sample print function<sup>\*1</sup> is one of the features provided for making multiple print sets and allows you to confirm that the finish is as expected before starting a long print run.

\*1 Optional Printer Hard Disk Type 185 required.

### ❖ Versatile Paper Handling Options

This printer offers both versatile input and output paper handling options. Input capacity can be raised to 3,100 sheets with the optional paper bank (PS420) and the bypass tray (Type 270) to reduce the inconvenience of reloading paper. With the optional mailbox (CS370), you can specify up to five print delivery destinations, including the standard output tray, to prevent your prints being mixed up with other peoples. In addition, collation<sup>\*2</sup> and stapling<sup>\*2</sup> are available with the optional finisher (SR510 or SR720).

\*2 Optional Memory Unit TypeB (32 MB, 64 MB or 128 MB) or Printer Hard Disk Type 185 required.

### ❖ Variety of Paper Media Support

Standard tray 2 and optional Bypass Tray Type 270 support a variety of print media such as thick paper<sup>\*3</sup>, transparencies<sup>\*3</sup> and certain envelopes<sup>\*3</sup>.

\*3 For more information about the supported paper and other media, see "Paper and Other Media" in the Printer Reference included as a PDF file on the CD-ROM.

### ❖ Network Interface Board Standard<sup>\*4</sup>

This printer comes with network-ready Ethernet capability supporting multiple protocols as standard. This feature can be used in a variety of network environments.

\*4 For more information about configuring the printer for a network, see the Operating Instructions for the Network Interface Board included as a PDF file on the CD-ROM.

### ❖ Adobe PostScript 3 Standard

In addition to PCL 6 emulation, Adobe PostScript 3 is provided as a standard feature. This feature can be used in Macintosh environments as well. Adobe applications can be printed properly and easily.

### ❖ Network Utility

PRINTER MANAGER\*5, software consisting of ADMINISTRATOR and CLIENT versions, is provided. With this software, multiple print devices can be utilized effectively together on a network. This software offers several convenient functions such as parallel printing and recovery printing.

\*5 For the name of the PRINTER MANAGER application you have, see the inside of front cover of this manual.

### ❖ Major Specifications

Continuous Printing Speed	32 ppm (A4 long-edge feed or 8 1/2" × 11" long-edge feed, simplex) 25 ppm (A4 long-edge feed or 8 1/2" × 11" long-edge feed, duplex)
Resolution	Max. 600 dpi resolution plus enhanced resolution with edge smoothing
Printer Languages	PCL 5e Emulation, PCL 6 Emulation Adobe PostScript 3
Paper Input Capacity	500 sheets × 2 trays Max. 3,100 sheets with options
Paper Output Capacity	500 sheets Max. 1,750 sheets with options
Memory	32 MB Max up to 160 MB
HDD	6.0 GB or more (option)
Interface	10BASE-T or 100BASE-TX × 1 IEEE1284 × 1
Options	PS440 (1000-sheet paper feed unit) PS420 (2000-sheet paper feed unit) Interchange Unit Type 280 Bypass Tray Type 270 AD380 (duplex unit) CS370 (mailbox) Bridge Unit Type 320 SR510 (500-sheet finisher) SR720 (1000-sheet finisher) Memory Unit TypeB (32 MB/64 MB/128 MB) Printer Hard Disk Type 185

## Printer Drivers for This Printer

Printing requires installation of a printer driver appropriate to the operating system. The following drivers are included on the CD-ROM that comes with this printer.

Operating system	Printer Language		
	PCL 5e	PCL 6	PostScript 3
Windows 95 <sup>*1</sup>	√	√	√ <sup>*9</sup>
Windows 98 <sup>*2</sup>	√	√	√ <sup>*9</sup>
Windows Me <sup>*3</sup>	√	√	√ <sup>*9</sup>
Windows 2000 <sup>*4</sup>	√	√	√ <sup>*9</sup>
Windows NT 4.0 <sup>*5</sup>	√	√ <sup>*7</sup>	√ <sup>*8</sup> <sup>*9</sup>
Macintosh <sup>*6</sup>			√ <sup>*9</sup>

<sup>\*1</sup> Microsoft Windows 95 operating system

<sup>\*2</sup> Microsoft Windows 98 operating system

<sup>\*3</sup> Microsoft Windows Millennium Edition (Windows Me)

<sup>\*4</sup> Microsoft Windows 2000 Professional, Microsoft Windows 2000 Server

<sup>\*5</sup> Microsoft Windows NT Server operating system Version 4.0, Microsoft Windows NT Workstation operating system Version 4.0 in a computer using a x86 processor.

<sup>\*6</sup> Macintosh in PowerPC running operating system version 7.6.1 ~ 9.0.

<sup>\*7</sup> Requires Service Pack 4 or later.

<sup>\*8</sup> Requires Service Pack 5 or later.

<sup>\*9</sup> The Adobe PostScript printer drivers and PostScript Printer Description (PPD) files are included on the CD-ROM.

### ❖ PCL Printer Drivers

Printer drivers allow the computer to communicate with the printer via a printer language. Two kinds of PCL printer drivers, PCL 6 and PCL 5e, are included on the CD-ROM that comes with this printer. We recommend PCL 6 as your first choice. However, some of the applications might require installation of the PCL 5e printer driver. In this case, you can install PCL 5e in addition to PCL 6.

#### Reference

For more information about installing the PCL 6/5e printer driver, see P.70 *"Installing the PCL 6/5e Printer Driver"*.

### ❖ Adobe PostScript Printer Drivers and PPD Files

The Adobe PostScript printer drivers and the PPD files are included on the CD-ROM that comes with this printer. The Adobe PostScript printer driver allows the computer to communicate with the printer via a printer language. The PPD files allow the printer driver to enable printer specific functions.

#### Reference

For more information about installing the PostScript printer driver, see P.72 *"Installing the PostScript Printer Driver"*.

# Software and Utilities Included on the CD-ROM

1

## ❖ **Agfa Font Manager**

Helps you to install new fonts, or organize and manage fonts already installed on your system.

## ❖ **PRINTER MANAGER FOR ADMINISTRATOR**

A utility for the system administrator to manage printers on the network.

### **Reference**

For the name of the PRINTER MANAGER FOR ADMINISTRATOR application you have, see the inside of front cover of this manual.

For more information, see the Help file.

## ❖ **PRINTER MANAGER FOR CLIENT**

A utility for users to manage their own print status on the network.

### **Reference**

For the actual name of the PRINTER MANAGER FOR CLIENT application you have, see the inside of front cover of this manual.

For more information, see the Help file.

## ❖ **PortNavi**

A utility that helps you to use network printers effectively. It is useful in environments where two or more network printers are used.

### **Reference**

For more information about using PortNavi, see the Operating Instructions for the Network Interface Board included as a PDF file on the CD-ROM.

## ❖ **Multidirect Print**

A utility for printing on a "Peer-to-Peer" network.

### **Reference**

For more information about Multidirect Print, see the Operating Instructions for the Network Interface Board included as a PDF file on the CD-ROM.

## ❖ **Acrobat Reader**

A utility that allows you to read PDF (Portable Document Format).

### **Note**

- Documentation about using the printer is included on the CD-ROM in a PDF format.



# Guide to the Printer

## Exterior: Front View

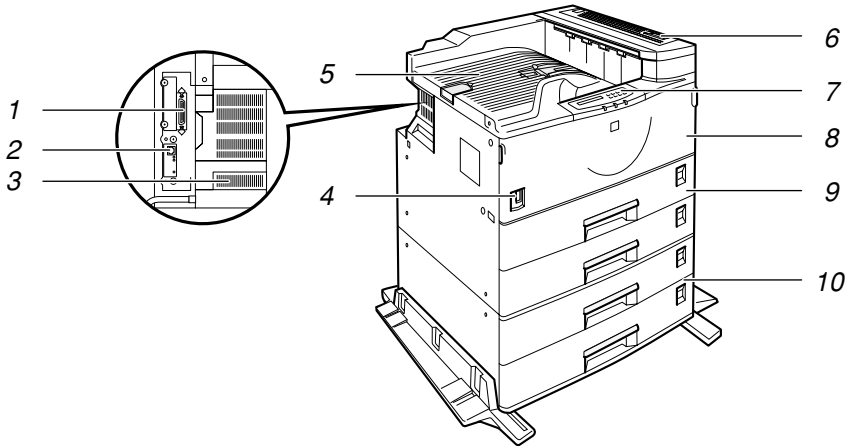

ZDEH010E

### 1. Parallel Interface Port

Plug the parallel cable into this port.

### 2. Network Interface Port

Plug the network cable into this port.

### 3. Ventilator

These holes help to keep components inside the printer from overheating. Do not lean anything against the printer, and do not block the ventilator.

### 4. Power Switch

Use this switch to turn the printer power on and off.

### 5. Output Tray

Printed output is stacked here with the print side face down.

### 6. Upper Right Cover

Open the upper right cover to remove misfed paper. Remove the upper right cover to install the optional interchange unit.

### 7. Operation Panel

Keys for operating the printer and a panel display that shows the printer status.  
⇒ P.8 "Operation Panel"

### 8. Front Cover

Open this cover to replace consumables or to view instructions for removing misfed paper.

### 9. Paper Tray

Load up to 500 sheets of plain paper (80 g/m<sup>2</sup>, 20 lb). The second tray from the top can load OHP transparencies or envelopes.

### 10. PS440 (Optional Paper Feed Unit)

Load up to 500 sheets of plain paper in its two trays. PS440 can hold up to 1000 sheets of plain paper (80 g/m<sup>2</sup>, 20 lb). PS420 can hold up to 2000 sheets of plain paper (80 g/m<sup>2</sup>, 20 lb).

---

## Exterior: Rear View

---

1

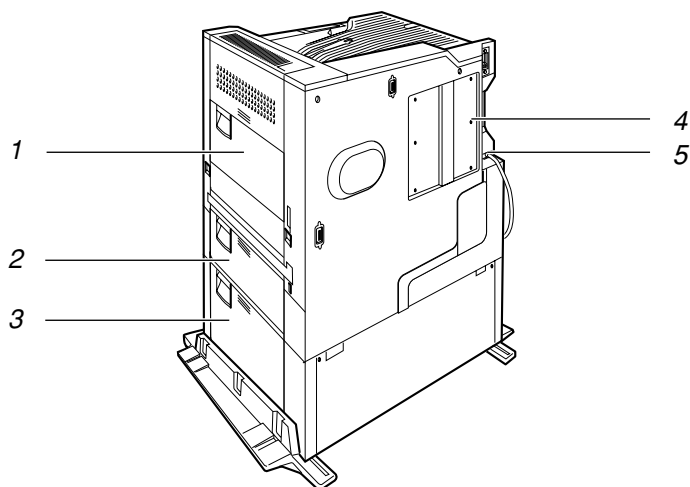

ZDEH020E

### **1. Right Cover**

Open this cover to replace the fusing unit or transfer roller, or to remove the misfed paper.

### **2. Lower Right Cover 1**

Open this cover to remove misfed paper.

### **3. Lower Right Cover 2**

Open this cover to remove misfed paper.

### **4. Printer Board Cover**

Open this cover to install Memory Unit TypeB, Printer Hard Disk Type 185 or both.

### **5. Power Cord**

Plug this cord into a wall outlet.

---

## Interior

---

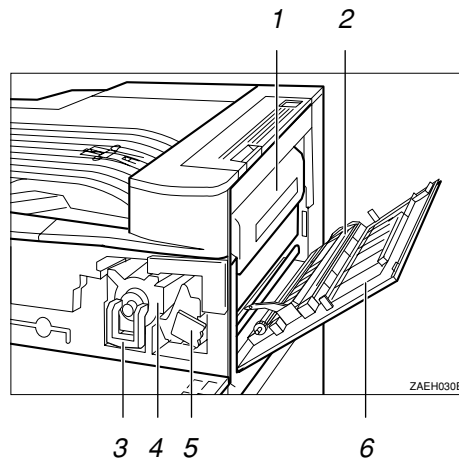

### 1. Fusing Unit

When “Replace Maintenance Kit” appears on the panel display, replace this unit.

### 2. Transfer Unit

When “Replace Maintenance Kit” appears on the panel display, replace this unit.

### 3. Toner Lock Lever

Lift this lever when replacing the toner.

### 4. Toner Holder

Slide this out when replacing the toner.

### 5. Photoconductor Unit

When “Replace PCU” appears on the panel display, replace this unit.

### 6. Right Cover

Open this cover to access the inside of the printer.

# Operation Panel

1

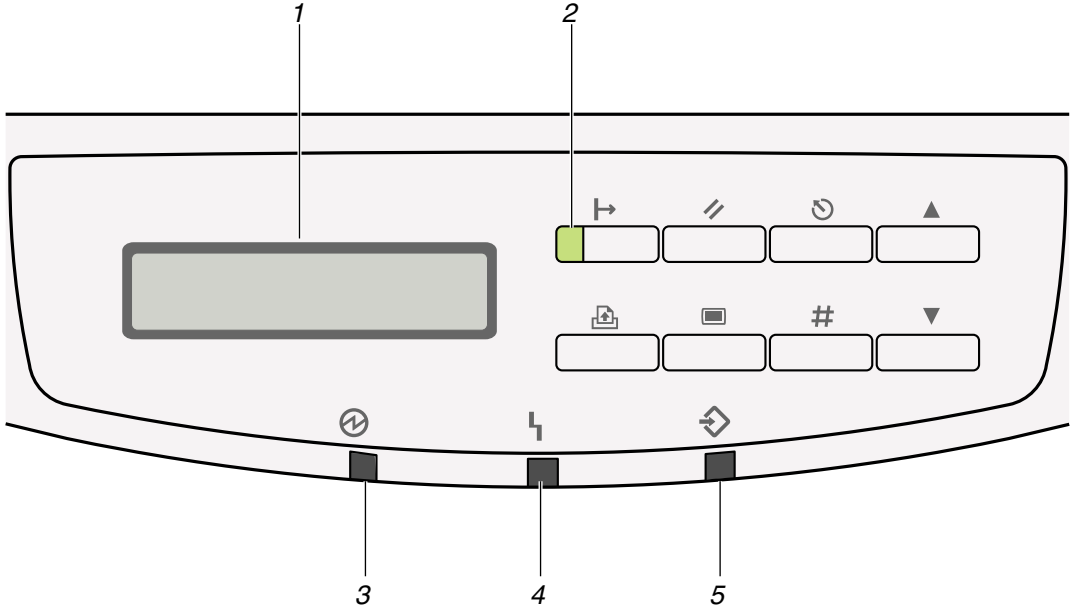

ZAES011E

### 1. Panel Display

Shows the current status of the printer and error messages. For more information about the messages, see “Error & Status Messages on the Operation Panel” in the Printer Reference included as a PDF file on the CD-ROM.

### 2. On Line Indicator

Tells you whether the printer is online or offline.

Stays on while the printer is online (a state in which the printer can receive data from the computer).

Stays off when the printer is offline (a state in which the printer cannot receive data).

### 3. Power Indicator

Stays on while the printer power is on. Stays off when the power is turned off or while the printer is in the Energy Saver mode.

### 4. Error Indicator

Lights up whenever any printer error occurs. A message describing the cause of the error also appears on the panel display. For more information about the messages, see “Error & Status Messages on the Operation Panel” in the Printer Reference included as a PDF file on the CD-ROM.

### 5. Data In Indicator

Blinks while the printer is receiving data from a computer or there is data to be printed.

## Keys

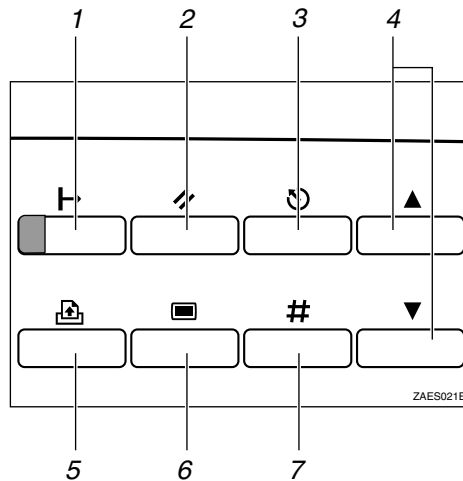

### 1. **[On Line]** key

Press this key to switch the printer online or offline. When the printer is online, the printer can receive data from the computer.

### 2. **[Job Reset]** key

When the printer is online, press this key to cancel any ongoing print jobs.

### 3. **[Escape]** key

Press this key to escape from the setup menu, and to return to the upper level without making any changes.

### 4. **[▲][▼]** keys

Use these keys to scroll through the selected items and to adjust values on the panel display when making settings. To change the value more quickly, hold these keys down.

### 5. **[Form Feed]** key

If the printer is offline, press this key to print out all the data left in the printer's input buffer.

### 6. **[Menu]** key

Press this key to check or change the current printer settings and to switch the printer offline. To go back to the ready condition, press this key again.

### 7. **[Enter #]** key

Press this key to choose menu selected on the panel display, or to go to a lower level.

## Guides

1

The guides of the output tray minimize curling of printed output. Use these guides when you print on A3 short-edge feed, 11" × 17" short-edge feed size paper, or thin paper.

❖ **To print onto A3 short-edge feed or 11" × 17" short-edge feed size paper**

Raise the end fence.

The guide prevents pages from falling off of the output tray.

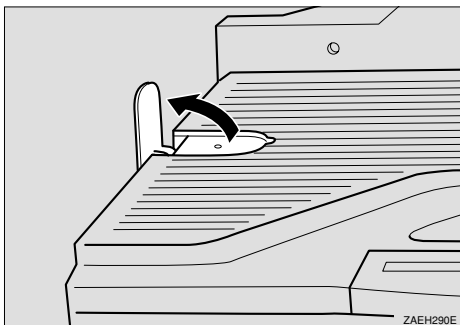

❖ **If either side of the page is curled, or if you print onto thin paper**

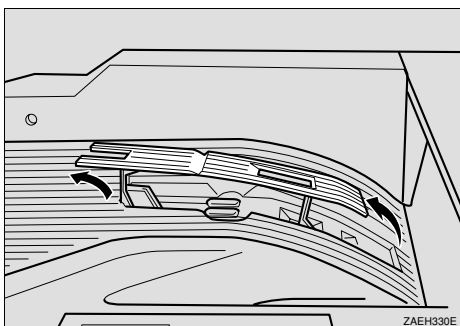

Raise the left end of the guide until it clicks into place.

The guide prevents printed pages from curling.

 **Note**

- ❑ If you use the guides, output capacity is reduced.

# 2. Setting Up the Printer

## Unpacking the Printer and Checking the Contents of the Box

### CAUTION:

- To prevent injuries, this printer should be lifted by at least two people.

**1** Check the contents of the box according to the following list. If any items are missing, please contact your sales or service representative.

- Setup Guide (this manual)
- Additional documentation
- CD-ROM labeled "Printer Driver and Utilities"
- Power cord
- Ferrite core
- Paper size seal
- Tray number seal

### Important

- The interface cable is not included in the box. It is your responsibility to provide the interface cable appropriate for the computer you are using. ⇒ P.56 "Connecting the Printer"
- The toner bottle is not included in the box. Consult your sales or service representative about the toner bottle.

**2** Remove the adhesive tape from the printer as shown in the illustration.

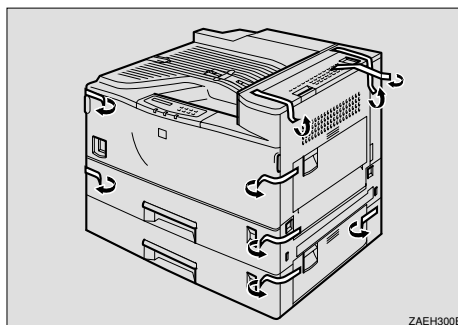

**3** Slide tray 2 out (①), and release the side guide adhesive lever (②), and then slide the side guide while pressing the release lever (③).

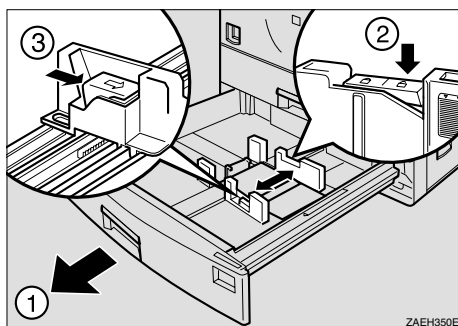

**4** Remove the adhesive tape.

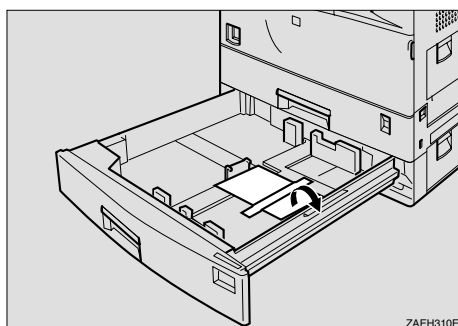

**5** Slide tray 1 out (①), and release the side guide adhesive lever (②), and then slide the side guide while pressing the release lever (③).

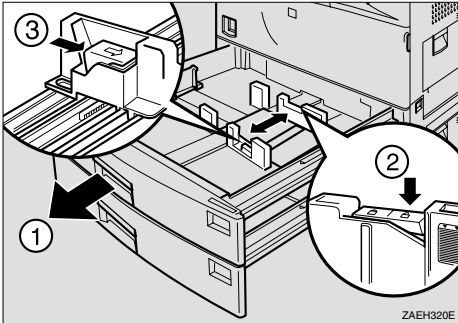

**6** Remove the adhesive tape.

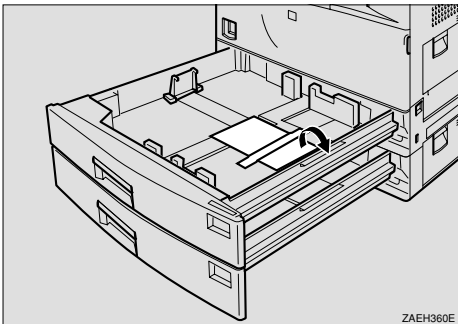

**7** Slide tray 1 and tray 2 into the printer until they stop.

**8** Open the front cover.

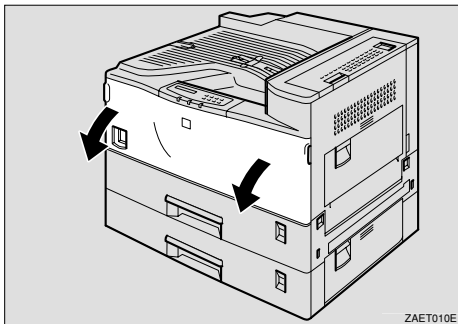

**9** Pull the three red tags on the photoconductor unit to remove the metal fitting and two tapes.

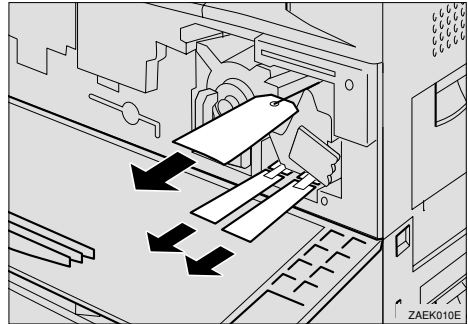

**Important**

Be sure to remove the red tags from the photoconductor unit. An error message will appear on the panel display if you turn on the printer power before the red tags are removed.

**10** Close the front cover.

**11** Set the paper sensor within the output tray on the top of the printer as shown in the illustration.

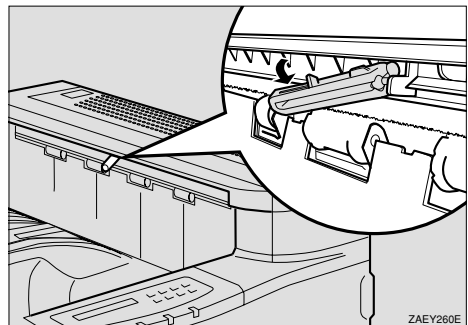

**12** Put the tray number seal directly below the paper size display on the front of the paper tray.

Unpacking of the printer is complete. For more information about installing options, see P.16 "Installing Options".



# Where to Put the Printer

**1** The printer's location should be carefully chosen because environmental conditions greatly affect its performance.

**⚠ WARNING:**

- ***Confirm that the wall outlet is near the machine and freely accessible, so that in the event of an emergency, it can be easily unplugged.***
- ***Only connect the machine to the power source described on this sheet.***
- ***Avoid multi-wiring.***
- ***Do not damage, break or make any modifications to the power cord. Do not place heavy objects on it, pull it hard or bend it more than necessary. These actions could damage the cord. A frayed or damaged cord might cause an electrical and fire hazard.***

**⚠ CAUTION:**

- *Do not handle the plug with wet hands. Doing this might cause an electrical shock.*
- *Keep the machine in an area that is within optimum environmental conditions. Operating the machine in an environment that is outside the recommended ranges of humidity and temperature can cause an electrical or fire hazard. Keep the area around the socket free of dust. Accumulated dust can become an electrical or fire hazard.*
- *Place the machine on a strong and level surface. Otherwise, the machine might fall and injure someone.*
- *If you use the machine in a confined space, confirm there is a continuous air turnover.*

❖ **Optimum Environmental Conditions**

Possible and recommended temperature and humidity ranges are as follows:

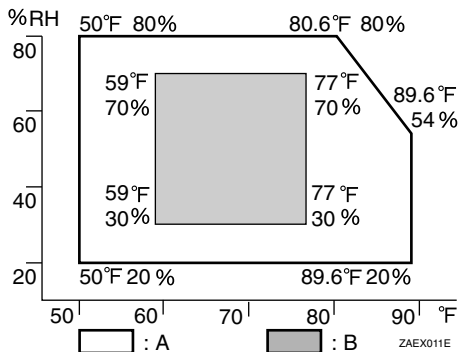
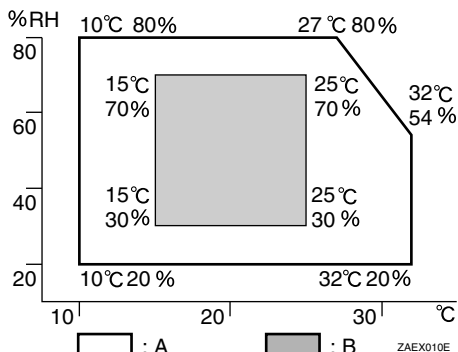

A: Possible range

B: Recommended range

The machine must be level within 5 mm, 0.2" both front to rear and left to right.

To avoid possible build-up of ozone, locate this machine in a large well ventilated room that has an air turnover of more than 30 m<sup>3</sup>/hr/person.

When you use this machine for a long time in a confined space without good ventilation, you may notice an odd smell. To keep the workplace comfortable, we recommend that you keep it well ventilated.

### ❖ Space Required for Installation

Leave enough space around the printer. This space is necessary to operate the printer. The recommended (or minimum) space requirements are as follows:

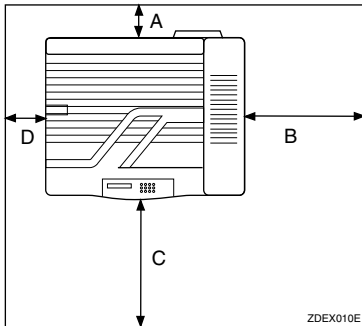

A: more than 10 cm (4.0")

B: more than 45 cm (17.8")

C: more than 75 cm (29.6")

D: more than 10 cm (4.0")

## 2 Environments to avoid

### ⚠ Important

- Locations exposed to direct sunlight or strong light
- Dusty areas
- Areas with corrosive gases
- Areas excessively cold, hot, or humid
- Locations near an air conditioner or humidifier
- Locations near other electronic equipment
- Locations where the printer might be subjected to frequent strong vibration

## 3 Power source

Connect the power cord to a power source with the following specifications:

- 220-240 V, 50/60 Hz, 4.5 A or more

## Installing Options

### **CAUTION:**

- *Before installing options, the machine should be turned off and unplugged for at least thirty minutes. Components inside the machine become very hot, and can cause a burn injury if touched.*
- *Before moving the machine, unplug the power cord from the outlet. If the cord is unplugged abruptly, it could become damaged. Damaged plugs or cords can cause an electrical or fire hazard.*
- *When lifting the machine, use the grips on both sides. The machine could break or cause an injury if dropped.*

You can increase the functionality of the printer by adding options. See "Options" in the Printer Reference included as a PDF file on the CD-ROM to confirm what kind of options are available.

If you want to install options, options should be installed in the order described below.

### **Important**

- Rating voltage of the connector for options: max. DC 24 V.

### **Note**

- If you want to install SR720 (1000-sheet finisher), Bridge Unit Type 320 and PS420 or PS440 are required.
- If you want to install SR720 (1000-sheet finisher), contact your sales or service representative.

## ❖ Option Installation Order

<b>1</b> <b>Installing the paper feed unit</b> ▼	There are two types of paper feed units: PS440 (1000-sheet paper feed unit) and PS420 (2000-sheet paper feed unit). Only one of them can be installed at once. ⇒ P.20 <i>“Installing PS440/PS420 (Paper Feed Unit)”</i>
<b>2</b> <b>Installing Interchange Unit Type 280</b> ▼	Interchange Unit Type 280 is used for AD380 (duplex unit) or CS370 (mailbox). If you want to install AD380 (duplex unit) or CS370 (mailbox), Interchange Unit Type 280 must be installed first. ⇒ P.24 <i>“Installing Interchange Unit Type 280”</i>
<b>3</b> <b>Installing AD380 (duplex unit)</b> ▼	Install AD380 (duplex unit) on the right side of the printer, after installing Interchange Unit Type 280. ⇒ P.26 <i>“Installing AD380 (Duplex Unit)”</i>
<b>4</b> <b>Installing Bypass Tray Type 270</b> ▼	Install Bypass Tray Type 270 on the right side of the printer. ⇒ P.30 <i>“Installing Bypass Tray Type 270”</i>
<b>5</b> <b>Installing Bridge Unit Type 320</b> ▼	Installing Bridge Unit Type 320 is used for SR510 (500-sheet finisher) or SR720 (1000-sheet finisher). If you want to install SR510 (500-sheet finisher) or SR720 (1000-sheet finisher), Bridge Unit Type 320 must be installed first. ⇒ P.33 <i>“Installing Bridge Unit Type 320”</i>
<b>6</b> <b>Installing SR510 (500-sheet finisher)</b> ▼	Install SR510 (500-sheet finisher) on the left side of the printer, after installing Bridge Unit Type 320. ⇒ P.35 <i>“Installing SR510 (500-sheet finisher)”</i>
<b>7</b> <b>Installing CS370 (mailbox)</b> ▼	Install CS370 (mailbox) on top of Interchange Unit Type 280, after installing Interchange Unit Type 280. ⇒ P.37 <i>“Installing CS370 (Mailbox)”</i>
<b>8</b> <b>Installing Memory Unit TypeB</b> ▼	There are three types of Memory Unit TypeB, 32 MB, 64 MB and 128 MB. Only one of them can be installed at once. ⇒ P.39 <i>“Installing Memory Unit TypeB”</i>
<b>9</b> <b>Installing Printer Hard Disk Type 185</b>	⇒ P.40 <i>“Installing Printer Hard Disk Type 185”</i>

## Available Options

The following options can be installed on the printer.

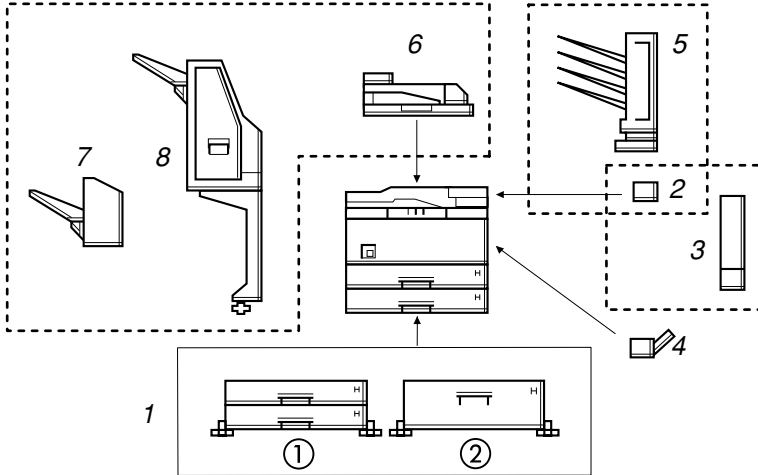

ZDEP011E

### 1. Paper Feed Units

Place the printer on the paper feed unit and fasten the screws that join the printer and the paper feed unit. There are two types of paper feed units that are described below. Only one of them can be installed at once.

#### ① PS440

With this option, you can load 1000 sheets.

#### ② PS420

With this option, you can load 2000 sheets.

### 2. Interchange Unit Type 280

With this option, the printed paper is sent to AD380 (duplex unit) or CS370 (mailbox).

### 3. AD380 (Duplex Unit)

With this option, you can print on both sides of paper. Install AD380 (duplex unit) on the right side of the printer, after installing Interchange Unit Type 280.

### 4. Bypass Tray Type 270

With this option, you can print on thick or custom size paper. You can load 100 sheets.

### 5. CS370 (Mailbox)

With this option, the printed paper can be sent to four output trays. Install CS370 (mailbox) on the top of Interchange Unit Type 280, after installing Interchange Unit Type 280.

### 6. Bridge Unit Type 320

With this option, the printed paper is sent to SR510 (500-sheet finisher) or SR720 (1000-sheet finisher).

### 7. SR510 (500-sheet Finisher)

With this option, up to 500 prints can be sorted or stapled at a time. Install this option on the left side of the printer, after installing Bridge Unit Type 320.

### 8. SR720 (1000-sheet finisher)

With this option, up to 1000 prints can be sorted or stapled.

**Note**

- ❑ If you want to install SR720 (1000-sheet finisher), Bridge Unit Type 320 and PS420 or PS440 are required.
- ❑ If you want to install SR720 (1000-sheet finisher), contact your sales or service representative.

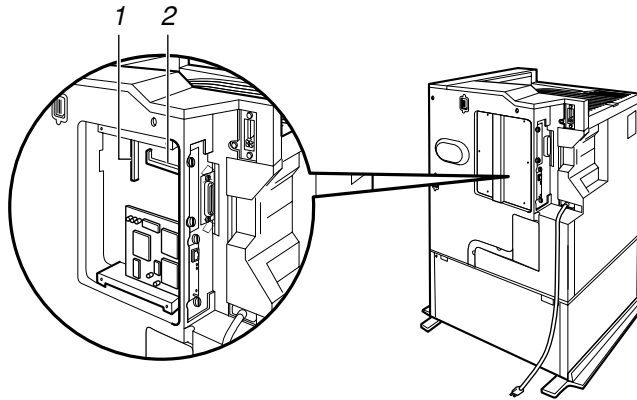

ZDEP020E

**1. Printer Hard Disk Type 185**

Install Printer Hard Disk Type 185 into the slots on the printer board.

**2. Memory Unit TypeB (32 MB, 64 MB or 128 MB)**

Install the memory unit into the slots on the printer board. There are three types of Memory Unit TypeB, 32 MB, 64 MB and 128 MB. Only one of them can be installed at once.

## Installing PS440/PS420 (Paper Feed Unit)

**⚠ CAUTION:**

- Before installing options, the machine should be turned off and unplugged for at least thirty minutes. Components inside the machine become very hot, and can cause a burn injury if touched.
- When lifting the machine, use the grips on both sides. The machine could break or cause an injury if dropped. It is dangerous to handle the plug with wet hands. Doing this may result in receiving an electric shock.
- Before moving the machine, unplug the power cord from the outlet. If the cord is unplugged abruptly, it could become damaged. Damaged plugs or cords can cause an electrical or fire hazard.

There are two types of paper feed units: PS440 (1000-sheet paper feed unit) and PS420 (2000-sheet paper feed unit). Only one of them can be installed at once. The installation of PS440 is described below.

**⚠ Important**

- ❑ You can load A4 long-edge feed (Metric version) or 8<sup>1</sup>/<sub>2</sub>" × 11" long-edge feed (Inch version) size into PS420. If you want to change the paper size A4 to 8<sup>1</sup>/<sub>2</sub>" × 11" (Metric version) or 8<sup>1</sup>/<sub>2</sub>" × 11" to A4 (Inch version), contact your sales or service representative.

**1** Confirm that the box contains the following items.

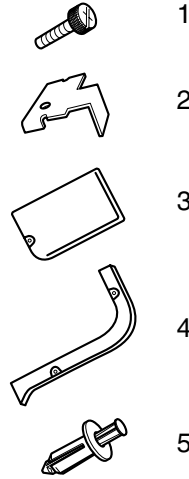

1. Screws (4 pcs)
  2. Securing brackets (2 pcs)
  3. Cover 1
  4. Cover 2
  5. Screws (3 pcs)
- Installation Guide

**✎ Note**

- ❑ The paper size seal and the tray number seal are included only with the printer.

**2** Turn off the printer, and remove all cables and cords from the printer.

ZAEP380E



- 3** Remove the adhesive tape and the packing materials.

**Important**

- Do not remove the adhesive tape holding the cable and the paper feed unit yet.

---

PS440

---

- 1** Remove the adhesive tape and the adhesive material.

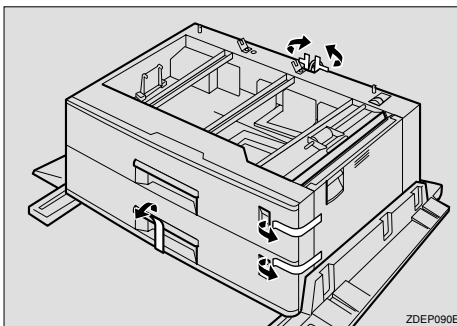

- 2** Slide out the first paper tray from the top, remove the packing material, and then remove the adhesive tape and adhesive material of the friction pad.

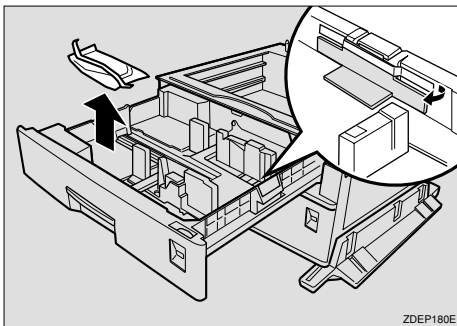

- 3** Return the first paper tray.  
**4** Slide out the second paper tray from the top, and then remove the adhesive tape and adhesive material of the friction pad.  
**5** Return the second paper tray.

---

PS420

---

- 1** Remove the adhesive tape and packing material.

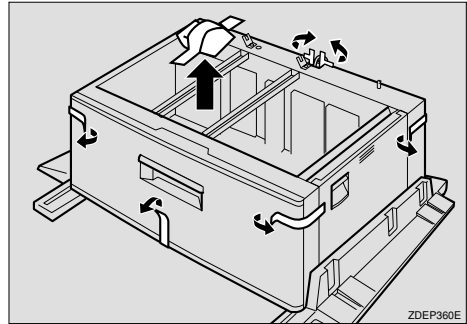

- 4** Slide out the four handles on both sides of the printer.

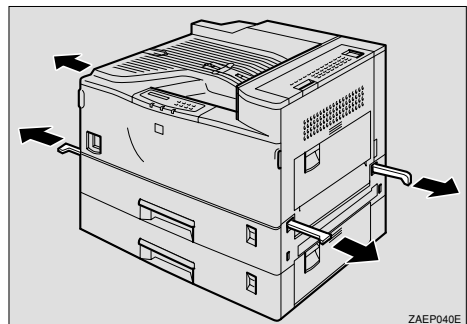

**5** By holding the handles, align the front face of the printer and the paper feed unit, then place the printer on the paper feed unit.

**Important**

□ The printer should be held by at least two people.

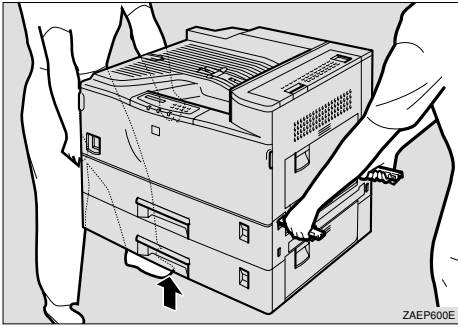

□ Do not pinch the harness on the back of the paper feed unit and the printer.

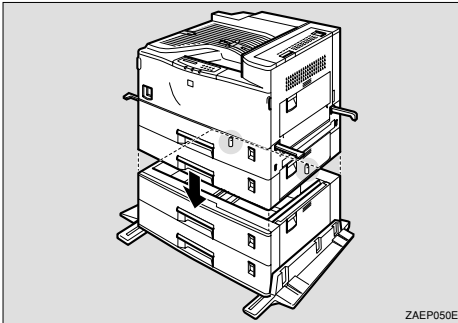

**6** Return the handles that were pulled out in step 4 to their original position.

**7** Slide tray 2 out until it stops. After that, lift the front, and pull it out.

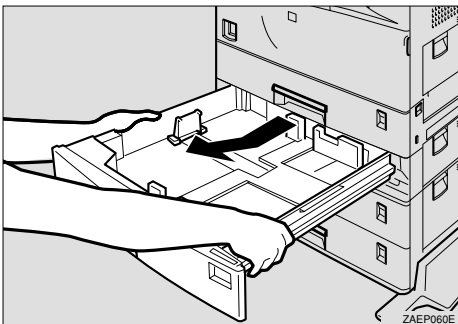

**8** Use a coin to fasten the two screws that join the paper feed unit and the printer.

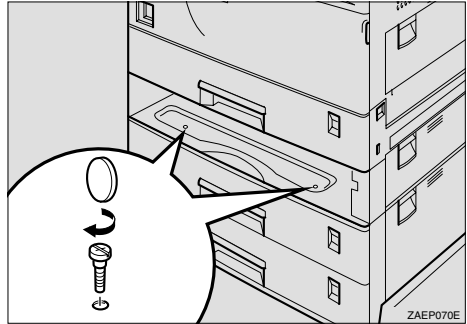

**9** Return tray 2.

**10** Attach the two securing brackets on the back of the printer and the paper feed unit, and fasten their screws using a coin.

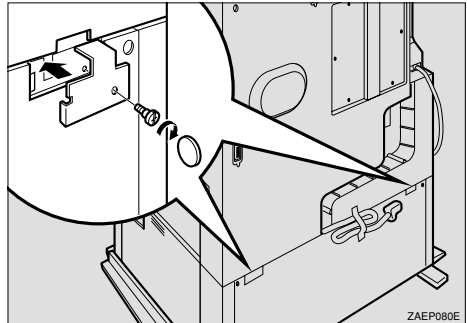

**11** Remove the adhesive tape holding the cable and connect the harness on the back of the printer.

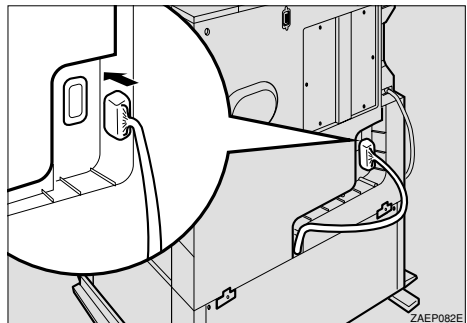

- 12** Push the cable of the connected harness into the groove for the cable.

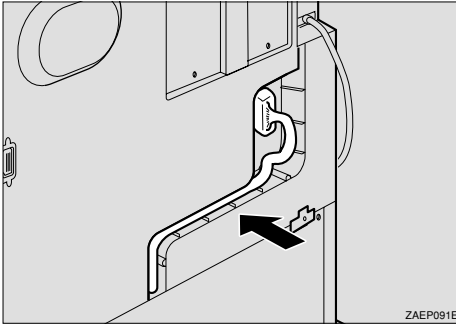

- 13** Attach cover 1 (①) and secure cover 1 to the printer fastening the screw (②).

**Note**

- Make sure the core of the screw is pulled out slightly before inserting it.

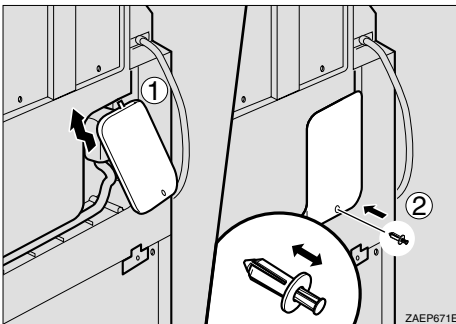

- 14** Attach cover 2 and secure cover 2 to the printer inserting the two screws.

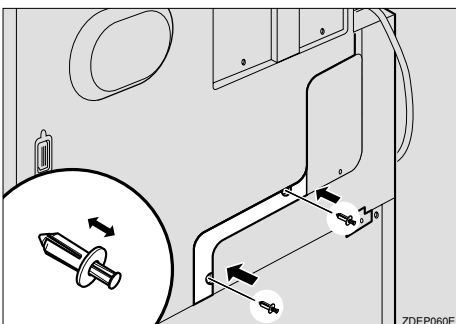

- 15** Turn the adjuster at the center bottom of the paper feed unit clockwise until it touches the floor.

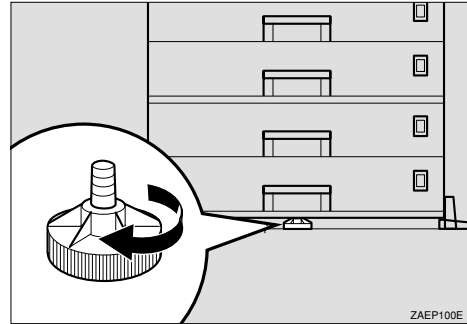

- 16** Put the seal directly below the paper size display on the front of the paper feed tray.

**Note**

- If PS440 is installed, use the tray number seal included with the printer.
- If PS420 is installed, use the paper size seal included with the printer.
- After installing all options, print a configuration page to confirm the installation. If the new device is listed in the column of configuration options, then it has been properly installed. For more information, see P.53 "Printing a Configuration Page".

## Installing Interchange Unit Type 280

**1** Confirm that the box contains the following item.

- Installation Guide

**2** Turn off the printer, and remove all cables and cords from the printer.

**3** Remove the adhesive tape and the packing materials.

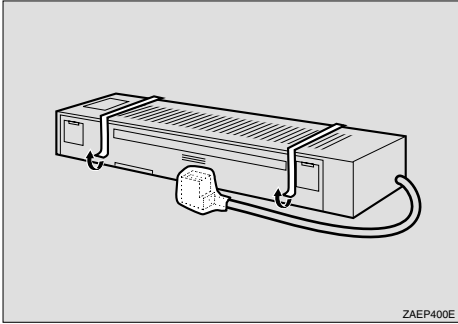

**4** Open the right cover of the printer by lifting the catch.

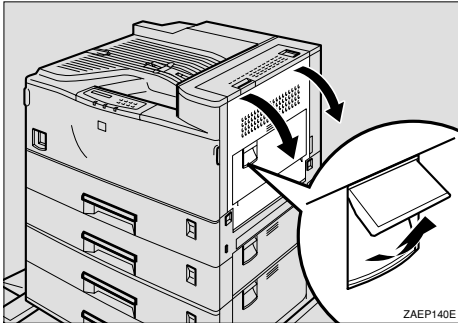

**5** Open the upper right cover by lifting the handle.

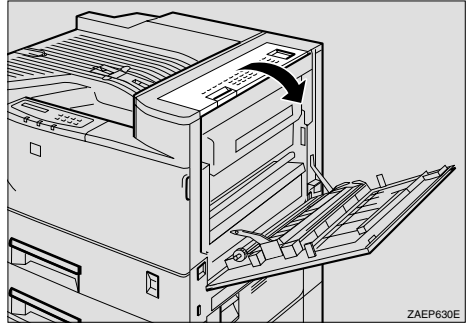

**6** Press the upper right cover in the direction as shown in the illustration (1), and remove the upper right cover (2).

**Note**

- The upper right cover is no longer required.

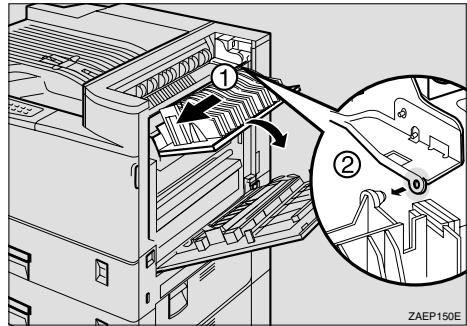

**7** Use a coin to remove the screw from the upper cover of the printer.

**Note**

- The removed screw is no longer required.

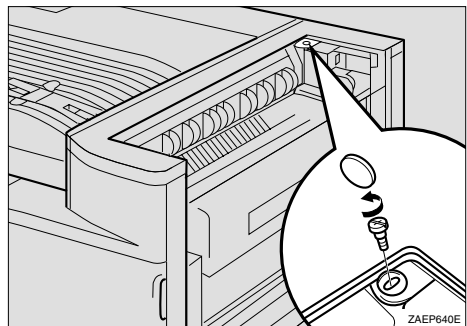

- 8** Put your fingers inside the upper cover of the printer and remove the cover by pulling upward.

**Note**

- The upper cover of the printer is no longer required.

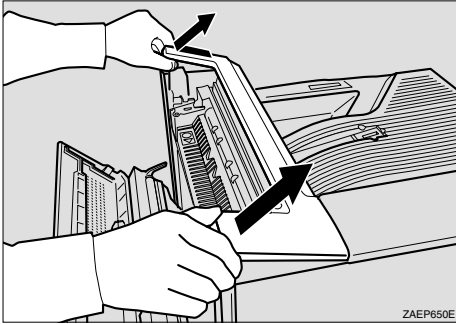

- 9** Remove the interchange unit cover from the interchange unit.

**Note**

- The removed cover is required in step 15.

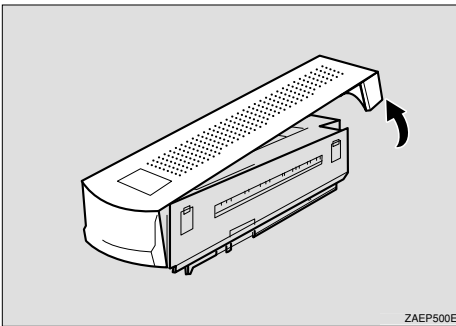

- 10** Move the cable to the back of the printer. Place the interchange unit onto the printer as shown in the illustration.

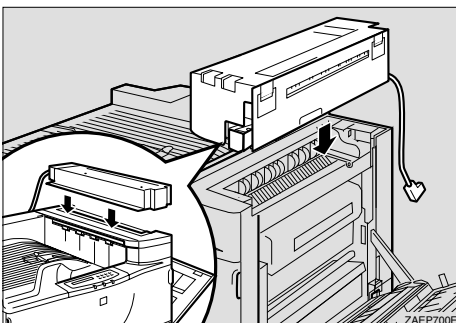

- 11** Open the upper right cover (1) and slide the interchange unit while keeping the cover perpendicular to the printer (2). At this time, confirm that the projection (3) is placed in the hole securely as shown in the illustration.

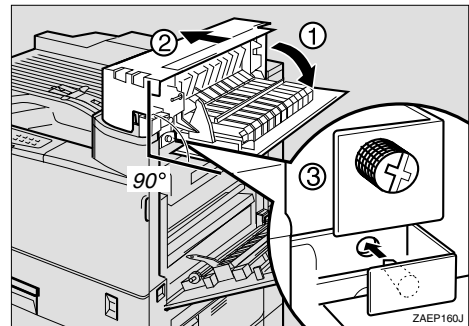

- 12** Fasten the two screws with fingers, while keeping the upper right cover of the interchange unit perpendicular to the printer, and secure the interchange unit to the printer. Use a coin to fasten the screws.

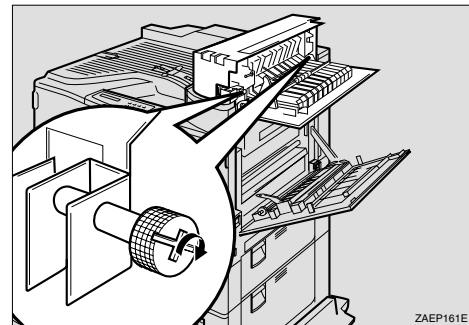

- 13** Close the upper right cover of the interchange unit.

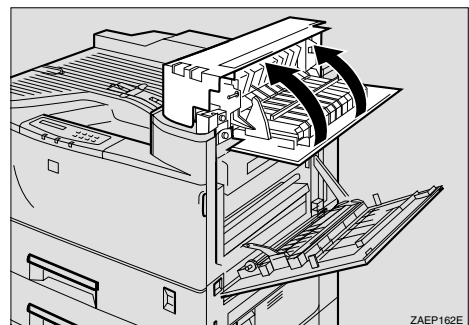

- 14** Close the right cover by pushing the area as shown in the illustration.

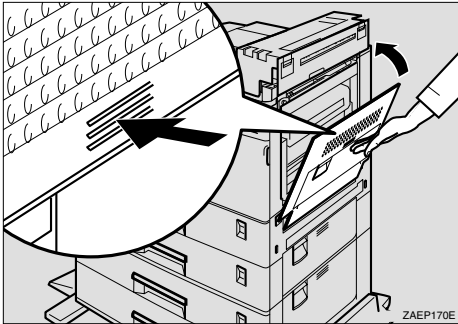

- 15** If the mailbox is not installed, attach the interchange unit cover that was removed in step 9. Attach the side of the cover facing the front of the printer first (1) and then the other side of the cover (2).

**Note**

- If you are going to install the mailbox, skip this step.

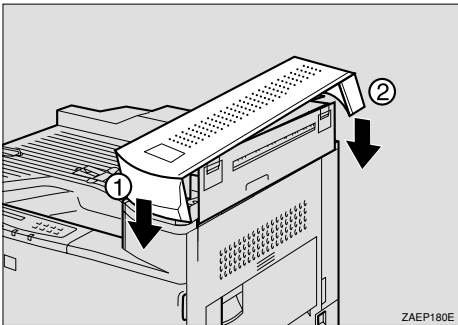

- 16** Attach the connector of the interchange unit to the socket on the back of the printer as shown in the illustration.

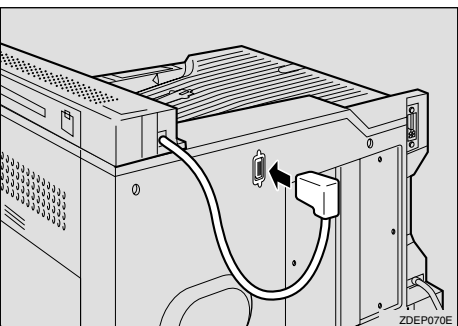

## Installing AD380 (Duplex Unit)

### Preparation

The installation procedure when the bypass tray unit is not yet installed is described below.

If the bypass tray unit is already installed, perform steps 9 to 10 of P.30 "Installing Bypass Tray Type 270". You can skip steps 5 to 8 below.

### Important

- If you install the duplex unit, the interchange unit must be installed first.

- 1** Confirm that the box contains the following items.

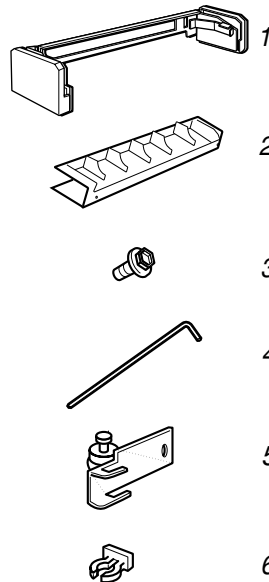

1. Holder
  2. Cover of the holder
  3. Socket screws (3 pcs)
  4. Wrench
  5. Hook
  6. Hook holder
- Installation Guide

ZAEP382E

**2** Turn off the printer, and remove all cables and cords from the printer.

**3** Remove the adhesive tape and the packing materials.

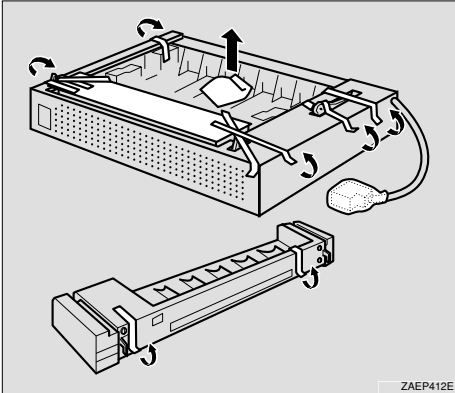

**4** Remove the two small covers from the top right side of the printer.

**Note**

- The removed small covers are no longer required.

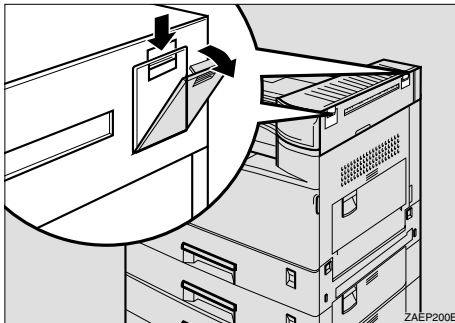

**5** Use a coin to remove the two screws on the right side of the printer.

**Note**

- The removed screws are no longer required.

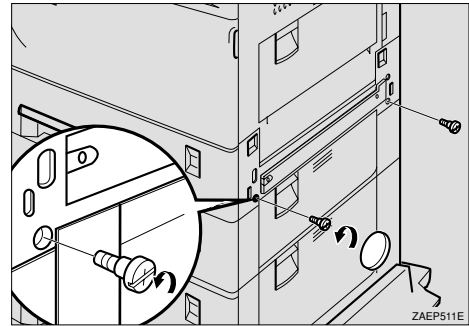

**6** Use the wrench to remove the two socket screws from the cover on the right side of the printer, and remove the cover.

**Note**

- Keep the removed screws and cover as they are required when removing the duplex unit.

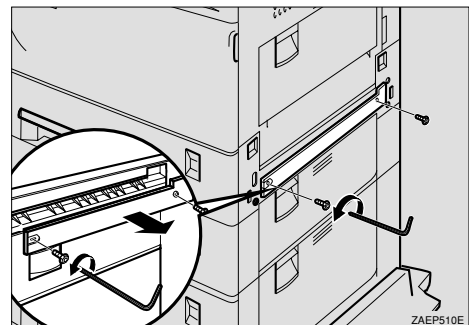

**7** Mount the brackets of the holder by placing them in the printer and pushing downwards slightly.

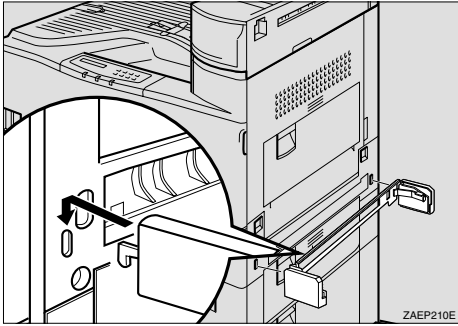

**8** Use the wrench to fasten the four socket screws in the order as shown in the illustration (① - ④), to secure the holder to the printer.

**Important**

□ The order to fasten the screws is: top right, top left, bottom right, and bottom left as viewed from the right side of the printer. If the screws were not fastened in that order, the duplex unit might not close completely or the bypass tray might not work correctly.

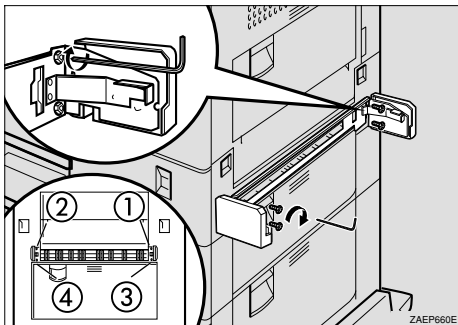

**9** Remove the small cover on the right side of the printer.

**Note**

□ The removed small cover is no longer required.

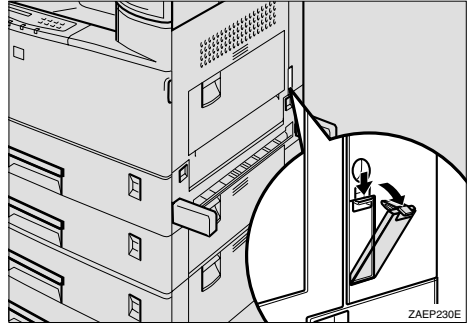

**10** Mount the brackets in the holes inside of the cover that was opened in step 9. Use the wrench to fasten the socket screw securing the hook to the printer.

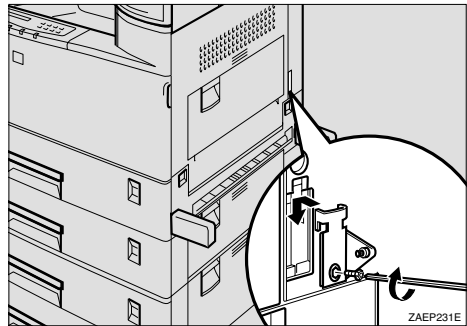

**11** Lower the duplex unit so that the groove in each arm of the unit forms a joint with the pin inside the holder as shown in the illustration.

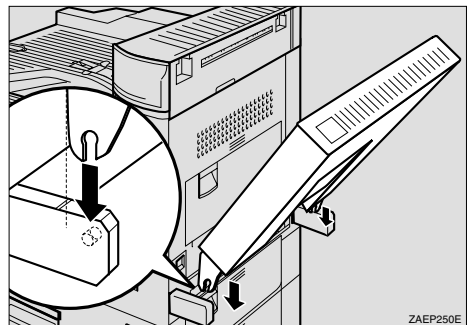



- 12** Hang the support bar in the duplex unit on to the hook that was attached in step 10 (1) and secure the bar by attaching the hook holder to the joint (2).

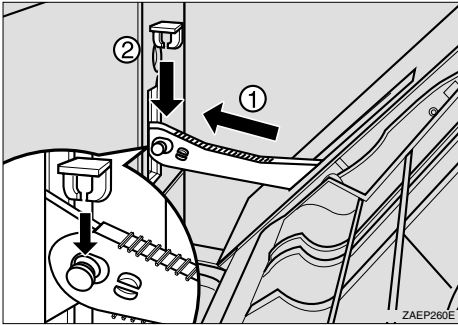

- 13** Close the duplex unit.

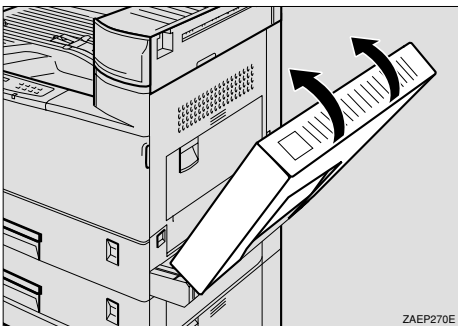

**Note**

- If the duplex unit is not closed completely, the holder was not installed properly in step 8. Fasten the socket screws securely in the order described in step 8.

- 14** Attach the connector of the duplex unit to the socket.

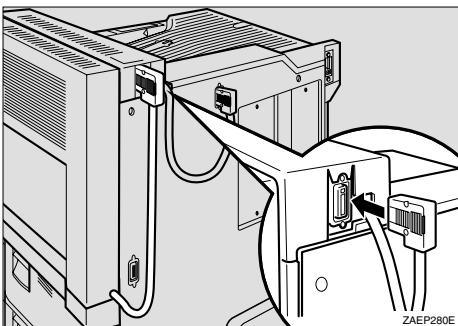

- 15** If the bypass tray is not installed, attach the cover of the holder. Use the wrench to fasten the two socket screws in the order as shown in the illustration to secure the holder to the cover.

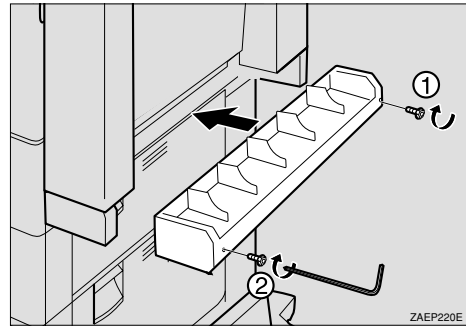

**Note**

- When installing the bypass tray, the cover of the holder is not required.
- Keep the wrench in the wrench house inside of the front cover.

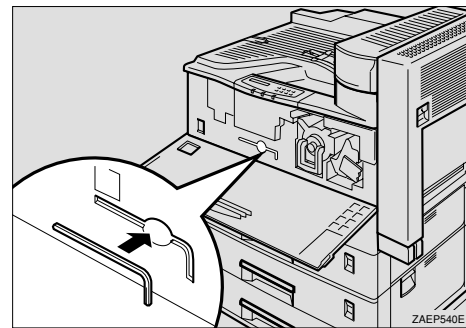

- After installing all options, print a configuration page to confirm the installation. If the new device is listed in the column of configuration options, then it has been properly installed. For more information, see P.53 "Printing a Configuration Page".

## Installing Bypass Tray Type 270

### Preparation

The installation procedure for installing the bypass tray when the duplex unit is not yet installed is described below.

If the duplex unit is already installed, remove the holder cover.

### Note

- ❑ If you install the duplex unit and the bypass tray unit, the duplex unit must be installed first.
- ❑ If the duplex unit is already installed, perform steps 1 to 3 and then go to step 8.

### 1 Confirm that the box contains the following items.

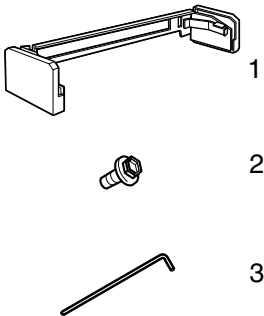

ZAEP430E

1. Holder

2. Socket screws (2 pcs)

3. Wrench

- Installation Guide

### Note

- ❑ If the duplex unit is already installed, the holder is no longer required.

### 2 Turn off the printer, and remove all cables and cords from the printer.

### 3 Remove the adhesive tape and the packing materials.

### Important

- ❑ Do not remove the adhesive tape (1) holding the tray and cable until the connector is attached in step 11.

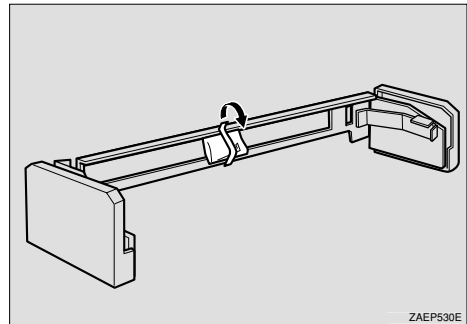
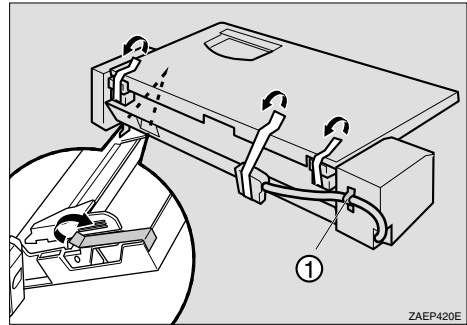

### Note

- ❑ If the duplex unit is already installed, go to step 8.

- 4** Use a coin to remove the two screws of the right side of the printer.

 **Note**

- The two removed screws are no longer required.

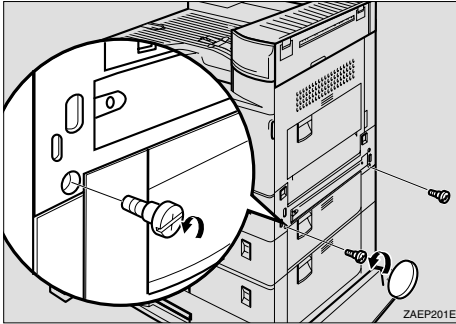

- 5** Remove the two socket screws holding the cover on the right side of the printer using the included wrench, and remove the cover.

 **Note**

- Keep the removed screws and cover as they are required when removing the duplex unit.

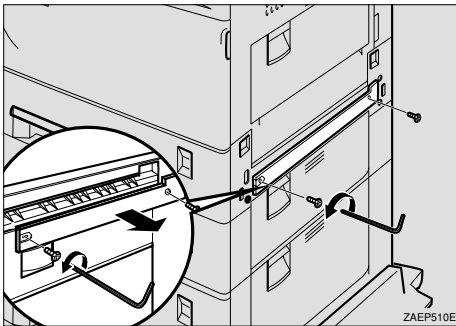

- 6** Mount the brackets of the holder by placing them in the printer and pushing downwards slightly.

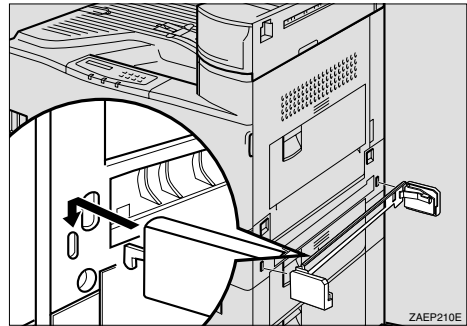

- 7** Use the wrench to fasten the four socket screws in the order shown in the illustration (① - ④), to secure the holder to the printer.

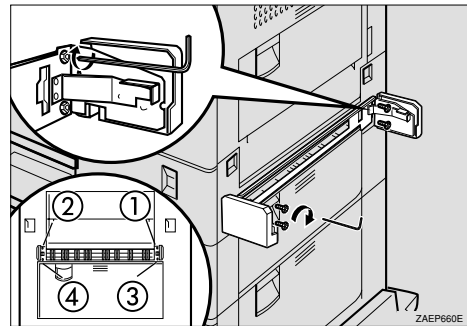

 **Important**

- The order to fasten the screws is: top right, top left, bottom right, and bottom left as viewed from the right side of the printer. If the screws were not fastened in that order, the duplex unit might not close completely or the bypass tray might not work correctly.

**8** If the duplex unit is not installed, skip this step and go to step 9. If the duplex unit is installed, the plastic edges on each side of the unit must be removed. The edges are held in place by four small posts. Twist the edges to break the posts and remove them from the unit.

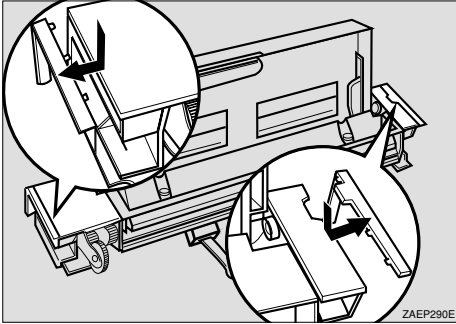

**9** Slide the bypass tray into the printer aligning the grooves of the right and left sides of the bypass tray onto the rails inside the holder.

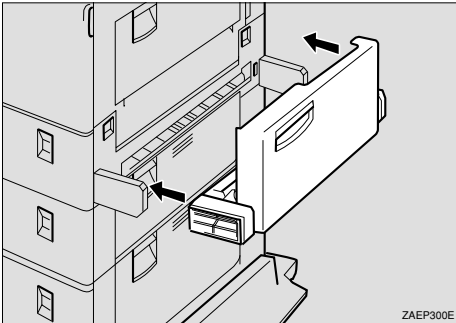

**10** Use the wrench to attach the bypass tray to the holder. Fasten the screws in the order shown in the illustration.

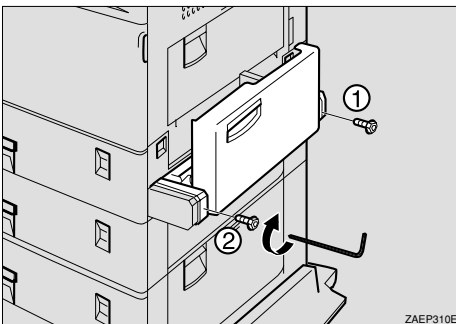

**11** Remove the adhesive tape holding the bypass tray and cable, and attach the connector to the socket on the left bottom side of the back of the printer.

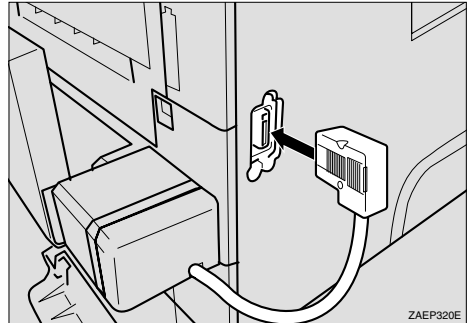

**Note**

- ❑ Keep the wrench in the wrench house inside of the front cover. Only one wrench can be kept in the wrench house.

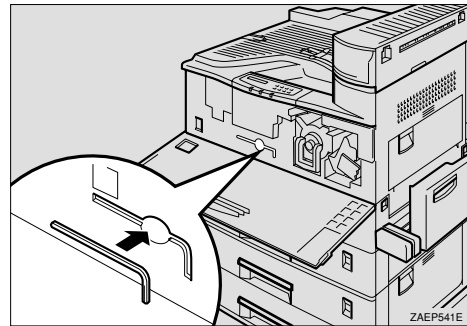

- ❑ After installing all options, print a configuration page to confirm the installation. If the new device is listed in the column of configuration options, then it has been properly installed. For more information, see P.53 "Printing a Configuration Page".

## Installing Bridge Unit Type 320

### Note

- If the mailbox is already installed, remove the four mailbox trays from the mailbox.

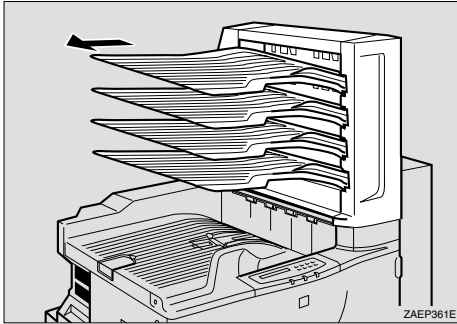

- 1** Confirm that the box contains the following items.

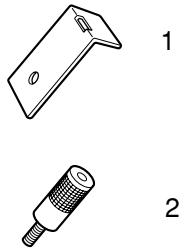

1. Connecting plate

2. Knob screws (2 pcs)

- Installation Guide

- 2** Turn off the printer, and remove all cables and cords from the printer.

- 3** Remove the adhesive tape.

### Important

- Do not remove the adhesive tape (①) holding the cable and the bridge unit until the connector is attached in step ④.

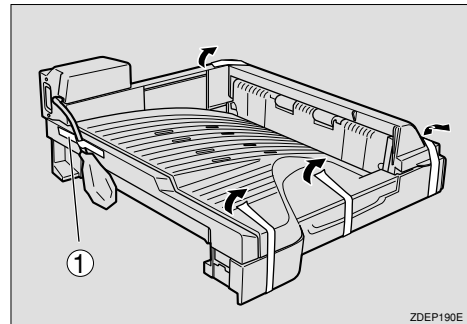

- 4** If the duplex unit is already installed, open the duplex unit by lifting the catch.

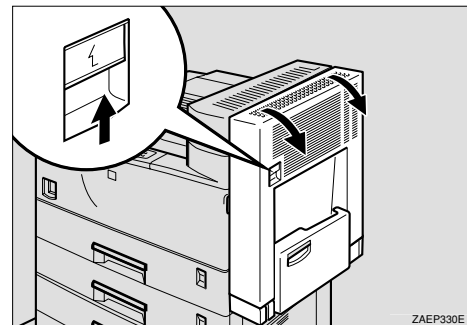

- 5** Open the right cover by lifting the catch.

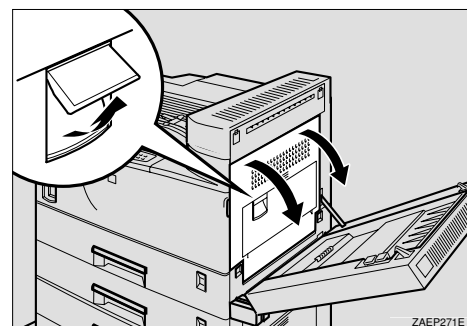

**6** Use a coin to remove the screw from the front right cover, and then remove the front right cover.

**Note**

- The front right cover has a clear film to prevent the removed screw falling in the printer. Do not remove the screw from the film.

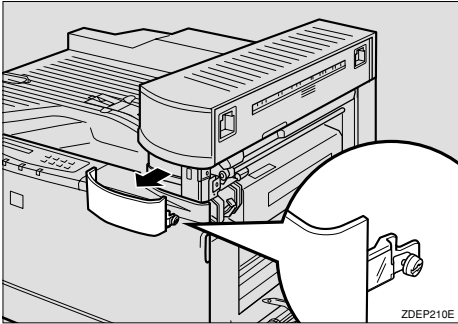

- The removed screw and cover are required in step 11.

**7** Use a coin to remove the screw, and then remove the cover as shown in the illustration.

**Note**

- The removed screw and cover are no longer required.

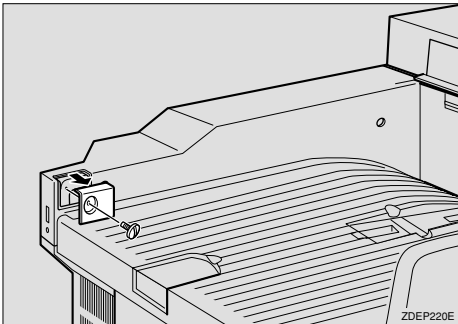

**8** Return the paper sensor into the output tray as shown in the illustration.

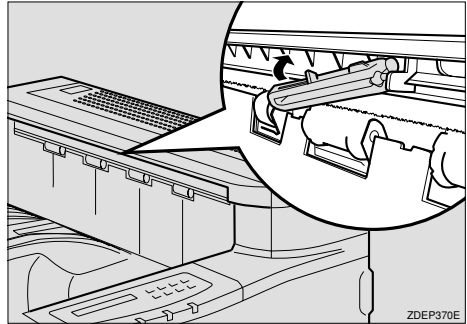

**9** Place the bridge unit on the output tray and slide the unit along the output part of the printer.

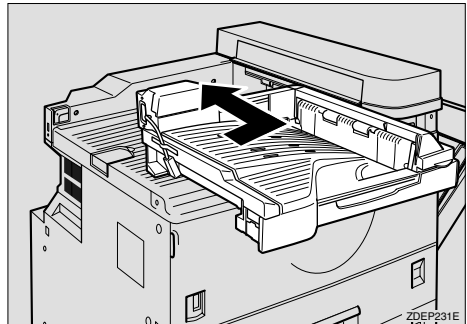

**10** Fasten the two knob screws and secure the bridge unit.

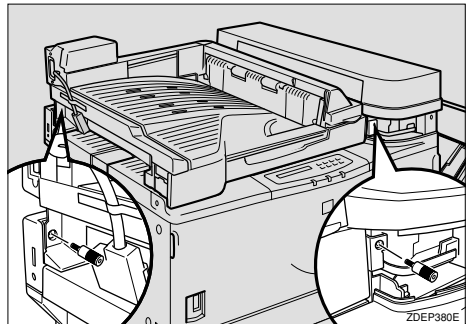

**11** Replace the front right cover removed in step 6, and then fasten the screw.

- 12** Close the right cover by pushing the area as shown in the illustration.

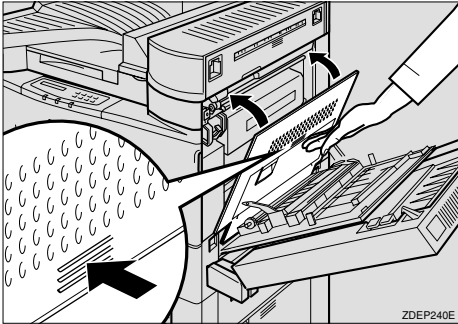

- 13** If the duplex unit is already installed, close the unit.

- 14** Remove the adhesive tape holding the bridge unit and cable and packing material, and attach the connector to the socket on the right top side of the back of the printer.

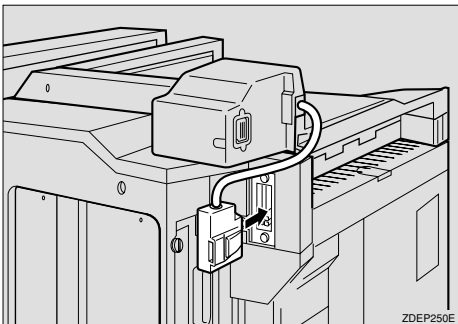

- 15** Attach the connecting plate as shown in the illustration.

**Note**

- The plate is fastened with a screw when installing the finisher.

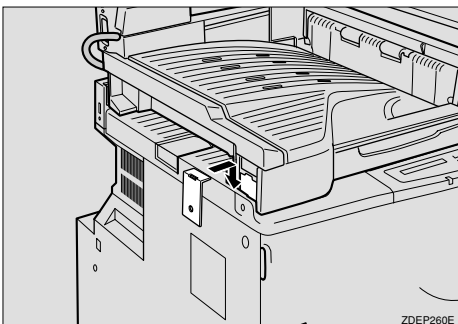

## Installing SR510 (500-sheet finisher)

**Note**

- If you install the finisher, the bridge unit must be installed first.

- 1** Confirm that the box contains the following items.

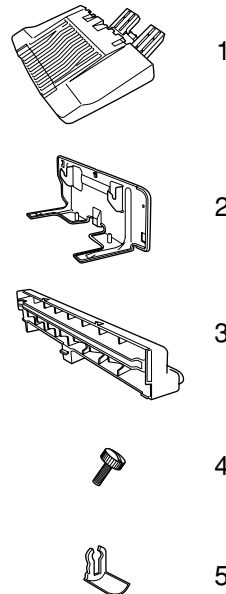

1. Finisher tray
2. Finisher stand
3. Output guide
4. Screws (2 pcs)
5. Stoppers (2 pcs)
  - Installation Guide

- 2** Turn off the printer, and remove all cables and cords from the printer.

**3** Remove the adhesive tape.

**Important**

- ❑ Do not remove the adhesive tape holding the finisher and cable until the connector is attached in step ⑩.

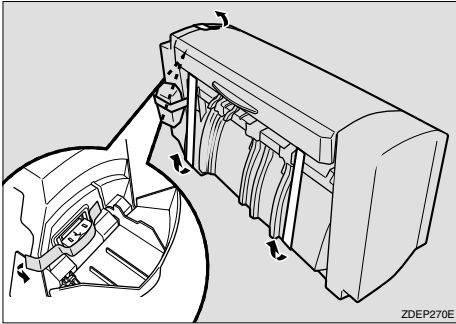

**4** Insert the output guide between the printer and the bridge unit.

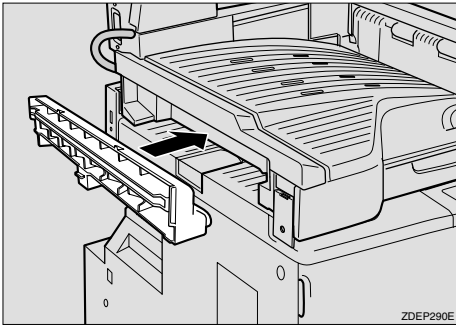

**5** Mount the brackets of the finisher stand by placing them in the printer, and then push it downwards slightly with catching it on the projection of the output guide (①).

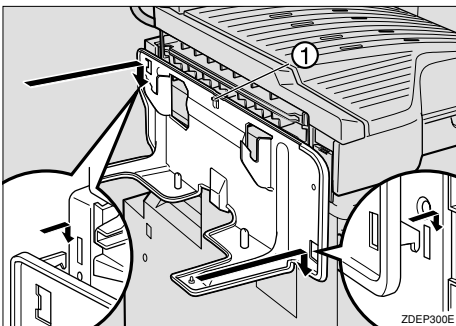

**6** Use a coin to fasten the screws, and secure the finisher stand to the printer

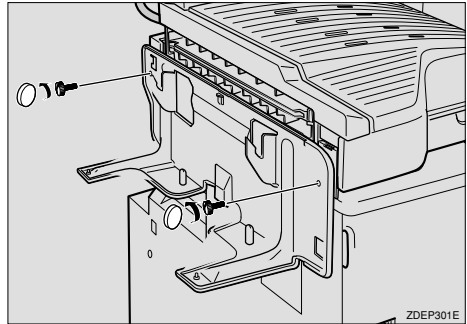

**7** Hold the finisher with both hands and keep it horizontal. Align the holes of the finisher over the brackets of the finisher stand, and then push the finisher downwards slightly.

**Note**

- ❑ If you do not keep the finisher horizontal, you cannot install it correctly. In this case, remove the finisher and reinstall it. For how to remove the finisher, see the Printer Reference included as a PDF file on the CD-ROM.

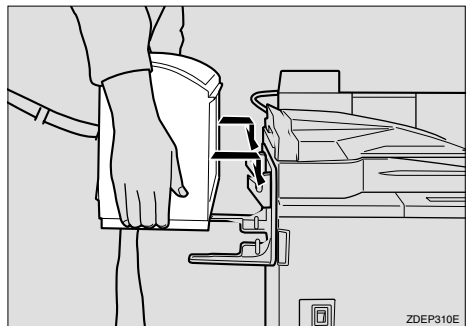



- 8** Insert the finisher tray into the hole of the finisher (①).

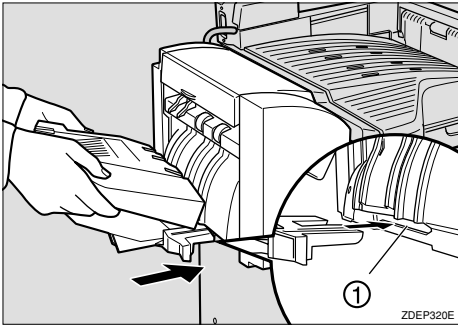

- 9** Attach the two stoppers to the lower of the finisher output tray to lock the tray.

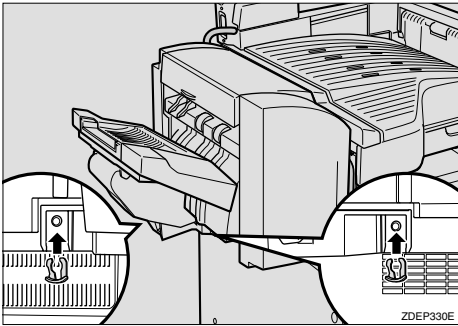

- 10** Remove the adhesive tape holding the finisher and cable and packing material, and attach the connector to the socket on the bridge unit.

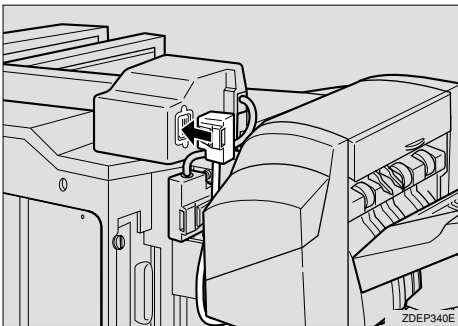

**Note**

- ❑ After installing all options, print a configuration page to confirm the installation. If the new device is listed in the column of configuration options, then it has been properly installed. For more information, see P.53 "Printing a Configuration Page".

## Installing CS370 (Mailbox)

**CAUTION:**

- When lifting the machine, use the grips on both sides. The machine could break or cause an injury if dropped.

**Note**

- ❑ If you install the mailbox, the interchange unit must be installed first.
- ❑ If you install the mailbox and the paper feed unit, the paper feed unit is recommended to be installed first.

- 1** Confirm that the box contains the following items.

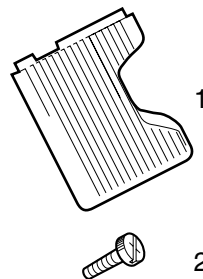

ZAEP383E

**1. Mailbox trays (4 pcs)**

**2. Screws (2 pcs)**

- Output tray number seal
- Installation Guide

**2** Turn off the printer, and remove all cables and cords from the printer.

**3** Remove the adhesive tape.

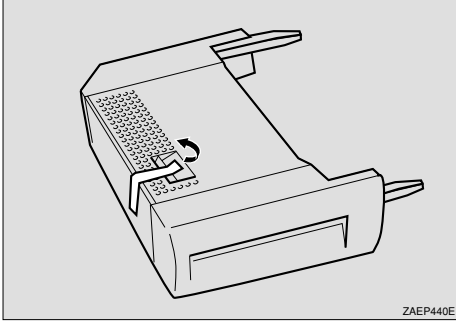

**4** If the duplex unit is already installed, open the duplex unit by lifting the catch.

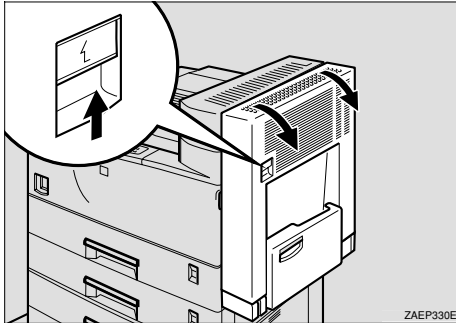

**5** Open the right cover by lifting the catch.

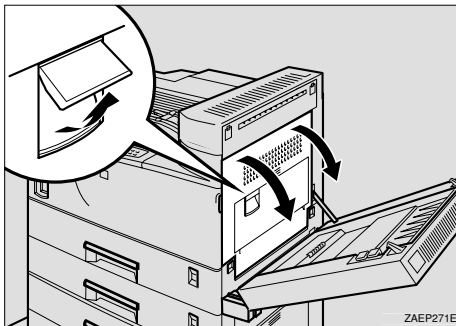

**6** If the cover of the interchange unit is attached, remove it by sliding it out toward the back of the printer.

**Note**

- If the cover of the interchange unit is already removed, go to step **7**.
- The removed cover is no longer required.

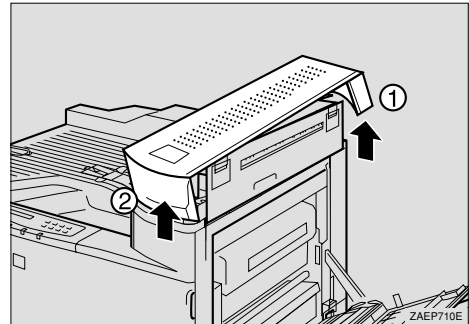

**7** Hold the mailbox on both sides and insert it into the printer from the top side of the printer.

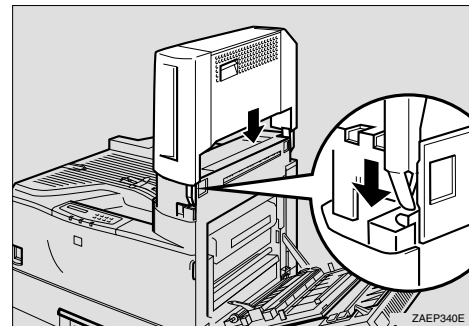

**8** Fasten the two screws by hand and secure the mailbox to the printer. Use a coin to fasten the screws securely.

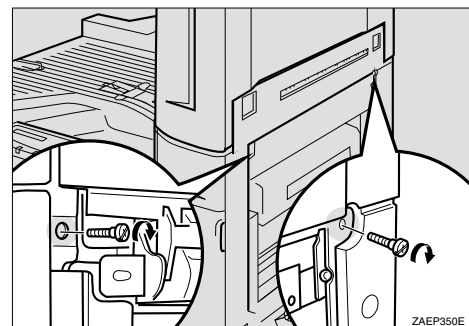

- 9** Close the right cover by pushing the area as shown in the illustration.

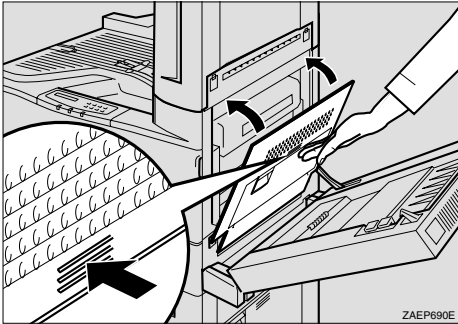

- 10** If the duplex unit is already installed, close the unit.

- 11** Slide the four mailbox trays into the lower side of the mailbox first.

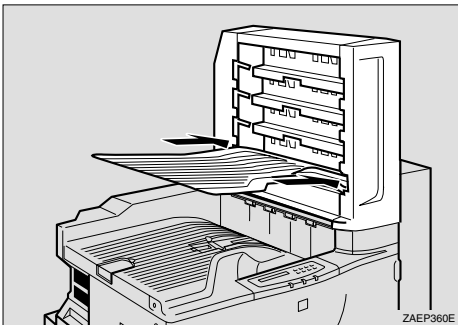

**Note**

- After installing all options, print a configuration page to confirm the installation. If the new device is listed in the column of configuration options, then it has been properly installed. For more information, see P.53 "Printing a Configuration Page".

## Installing Memory Unit TypeB

### Important

- The memory unit can be damaged by small amounts of static electricity. Before touching it, ground yourself by touching something metal to remove static electricity from you.

### Note

- If you want to install Memory Unit TypeB and Printer Hard Disk Type 185, Memory Unit TypeB must be installed first.

- 1** Confirm that the box contains the following item.

- Memory unit

- 2** Turn off the printer, and remove all cables and cords from the printer.

- 3** Use a coin to remove the six screws, and remove the printer board cover.

### Note

- The removed cover and screws are required in step **5**.

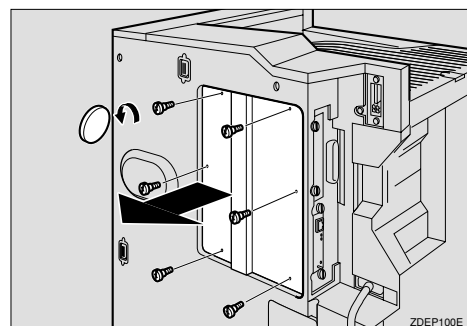

- 4** Tilt the memory unit so that it is thirty degrees perpendicular to the slot (①), and push it forward (②). It should click into place.

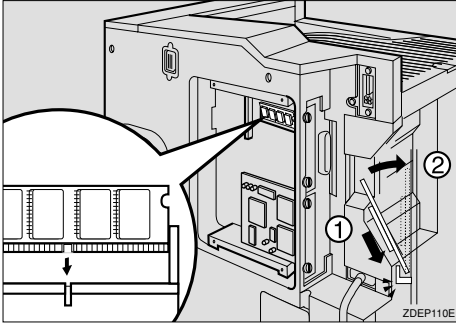

**Note**

- If the hard disk is already installed, remove the hard disk first.

- 5** Attach the printer board cover that was removed in step 3, and use a coin to fasten the six screws.

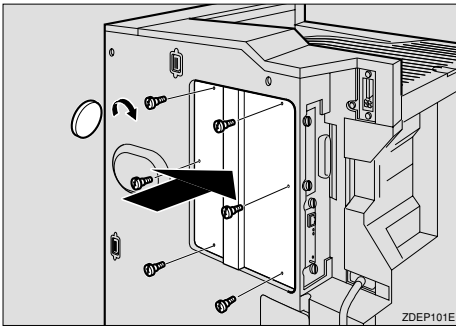

**Note**

- If you are now going to install the hard disk, it is not necessary to reattach the cover.
- After installing all options, print a configuration page to confirm the installation. If the new device is listed in the column of configuration options, then it has been properly installed. For more information, see P.53 "Printing a Configuration Page".

## Installing Printer Hard Disk Type 185

**Important**

- The hard disk can be damaged by small amounts of static electricity. Before touching it, ground yourself by touching something metal to remove static electricity from you.

- 1** Confirm that the box contains the following items.

- Hard disk
- Installation Guide

- 2** Turn off the printer, and remove all cables and cords from the printer.

- 3** Use a coin to remove the six screws, and remove the printer board cover.

**Note**

- The removed cover and screws are required in step 7.

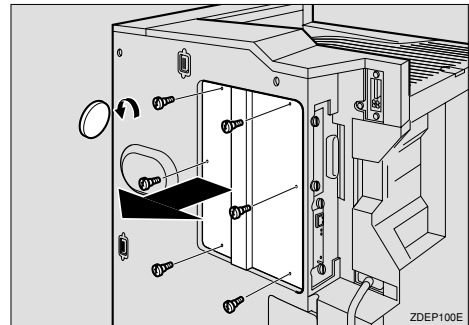

- 4** Use a coin to remove the two screws, and remove the cover.

**Note**

- The removed screws are required in step **6**.
- The removed cover is no longer required.

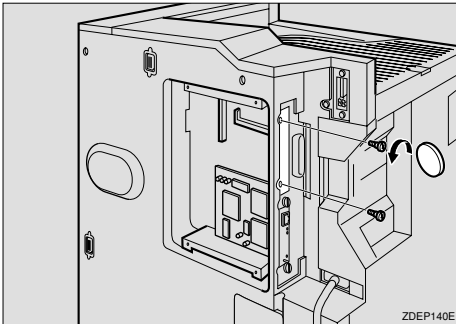

- 5** Align the hard disk interface connector over the printer interface port, and push gently but firmly on the hard disk until it is completely connected.

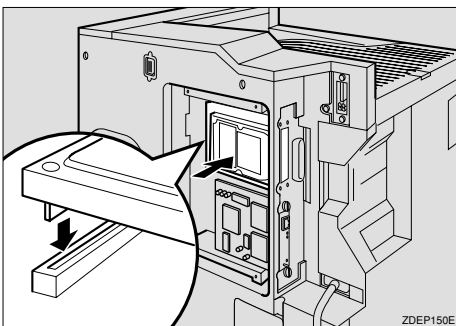

- 6** Fasten the two screws that were removed in step **4** to attach the hard disk to the printer.

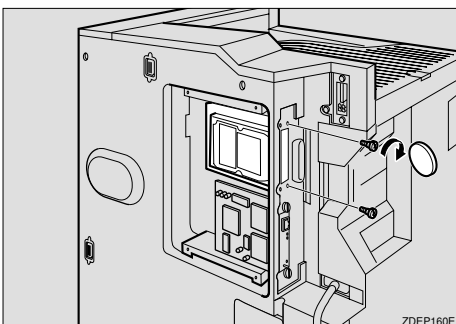

- 7** Attach the printer board cover that was removed in step **3**, and use a coin to fasten the six screws.

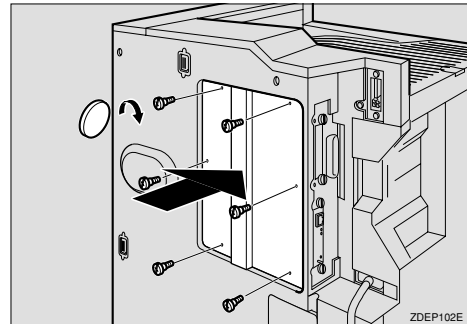

**Note**

- After installing all options, print a configuration page to confirm the installation. If the new device is listed in the column of configuration options, then it has been properly installed. For more information, see P.53 "Printing a Configuration Page".

# Installing the Toner Bottle

2

**⚠ WARNING:**

- *Do not incinerate spilled toner or used toner. Toner dust is flammable and might ignite when exposed to an open flame.*
- *Disposal should take place at an authorized dealer or an appropriate collection site.*
- *If you dispose of the used toner containers yourself, dispose of them according to local regulations.*

**⚠ CAUTION:**

- *The inside of the machine becomes very hot. Do not touch the parts with a label indicating a "hot surface". Touching a "hot surface" could result in a burn injury.*
- *Do not eat or swallow toner.*
- *Keep toner (used or unused) and the toner cartridge out of reach of children.*
- *Our products are engineered to meet the highest standards of quality and functionality. When purchasing expendable supplies, we recommend using only those provided by an authorized dealer.*

**1** Open the front cover.

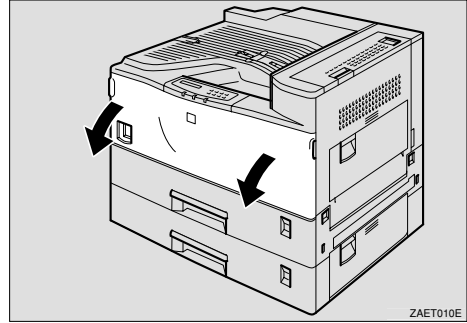

**2** Lift the green handle.

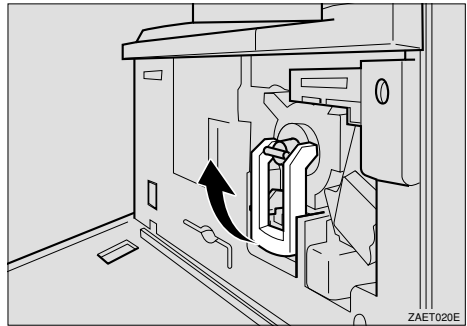

**3** While pushing the green lever (①), hold the handle and slide the toner holder out slightly (②).

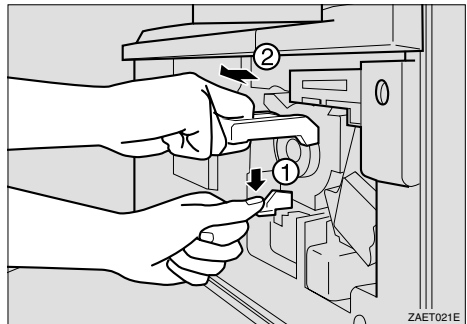

- 4** Release the green lever and slide the toner holder out until it stops gently.

**Important**

- If you continue to push the green lever to slide the toner holder, the toner holder might drop.

- 5** Move the new toner bottle back and forth about five or six times (①), and remove the black cap of the new toner bottle by turning it counterclockwise (②).

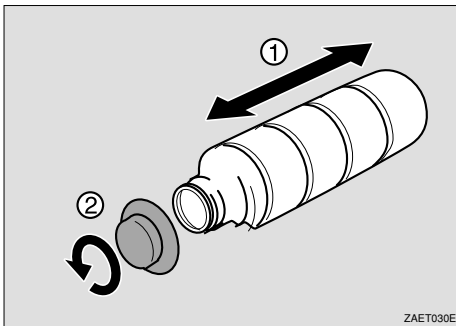

**Important**

- Do not remove the inside cap.

**Note**

- After removing the black cap from the bottle, toner can scatter easily. Do not shake or jar the bottle.

- 6** Put the toner bottle on the printer side of the toner holder (①), then push its head downwards to lock it in place (②).

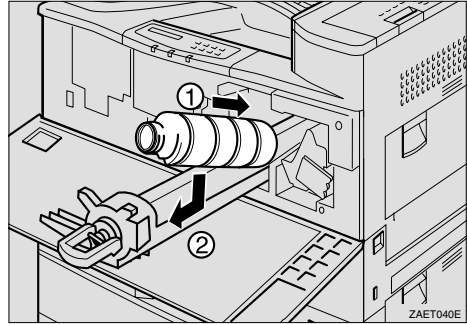

- 7** Slide the toner holder into the printer until it clicks into place, and push the green handle down.

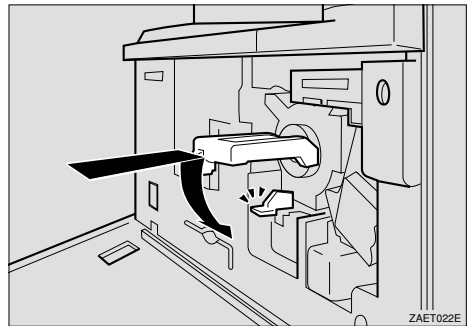

- 8** Close the front cover.

# Loading Paper

This section describes the type, size, feed direction, and maximum amount of paper that can be loaded into each paper tray in this printer.

2

## Reference

For more information about the size and feed direction of paper that can be set in the tray, see "Paper Type and Sizes" in the Printer Reference included as a PDF file on the CD-ROM.

## Loading Paper in the Paper Tray

This section describes instructions for loading paper in the standard paper tray and optional PS440. If you want to load paper in PS420, see P.47 "Loading Paper in PS420 (Paper Feed Unit)". If you want to load paper in Bypass Tray Type 270, see P.48 "Loading Paper in Bypass Tray Type 270".

**1** Slide the paper tray out until it stops.

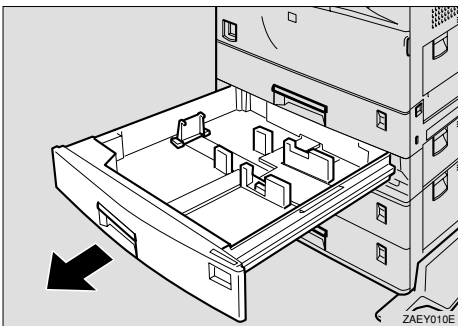

**2** Set the paper guide lock to the "unlocked" position.

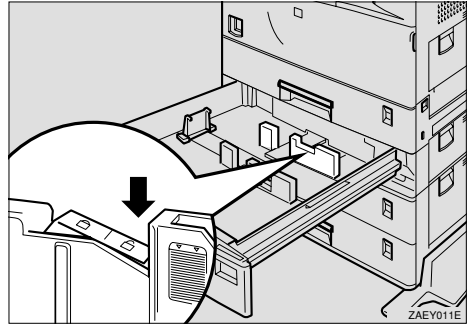

## Important

- ❑ Confirm that the lever of the side guide is released before sliding this guide or it can be damaged.

**3** Slide the side paper guide wide open (2) by pressing the release lever of the side guide (1).

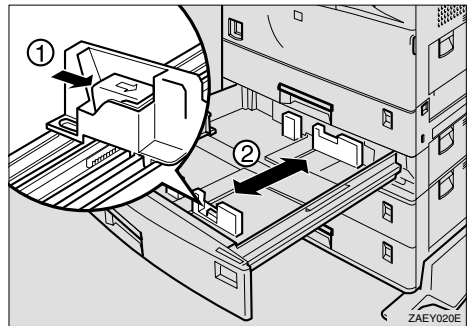



- 4** Align all four sides of the paper stack, and load it into the tray.

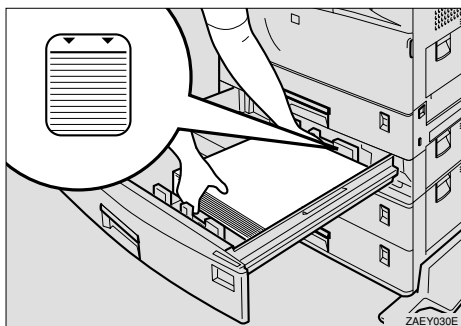

### Important

- Do not stack paper over the limit mark.
- When you set thick paper in tray 2, do not stack paper above the lower limit mark (①) of tray 2.

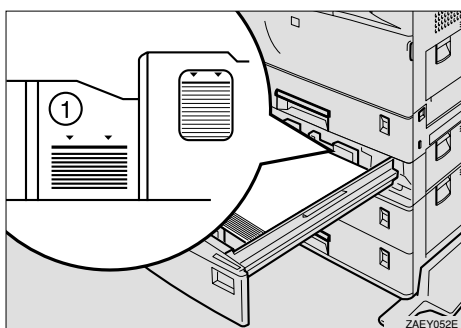

### Note

- To avoid paper multi-feeds, shuffle sheets before setting them in the tray.
- Load the paper face up onto the tray.

- 5** Align the side guide for the loaded paper size (②) by opening the release lever of the side guide (①).

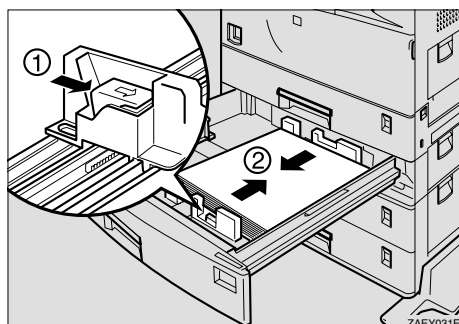

- 6** Set the paper guide lock to the "locked" position.

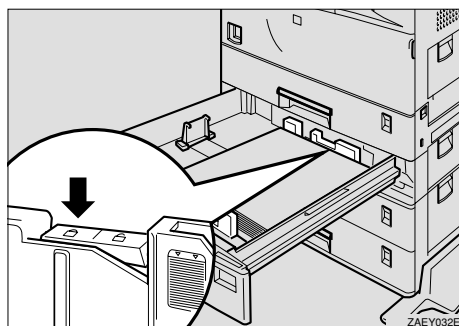

- 7** Align the rear guide for the loaded paper size slightly by pushing the releasing lever of the rear guide.

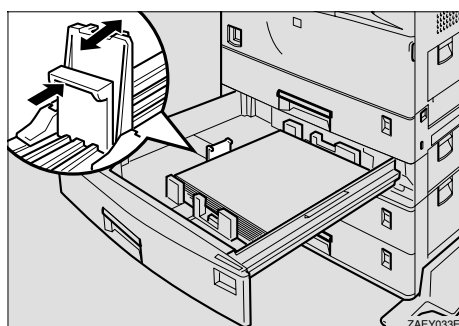

- 8** Adjust the paper size dial to match the size and feed direction of paper in the paper tray.

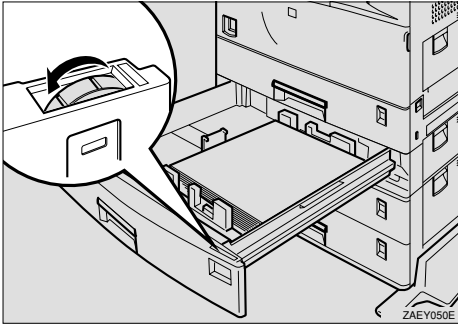

**Important**

- Confirm that the setting of the paper size dial matches the paper size and feed direction of the paper in the tray. If it does not, misfeeds or unexpected printing results may occur.
- When the actual paper size is not shown on the dial, set the dial to "\*" and select the paper size using the operation panel. For more information about setting up the paper size, see "Paper and Other Media" in the Printer Reference included as a PDF file on the CD-ROM.

**Note**

- Thick paper can be set in tray 2 of the printer or Bypass Tray Type 270. For more information about loading paper in the bypass tray, see P.48 "Loading Paper in Bypass Tray Type 270". When thick paper is placed in tray 2, move the lever on the paper size dial of tray 2 (1) to "Non-Standard Paper" mode. For more information about loading paper, see "Loading Thick Paper, Envelope or OHP Transparencies" in the Printer Reference included as a PDF file on the CD-ROM.

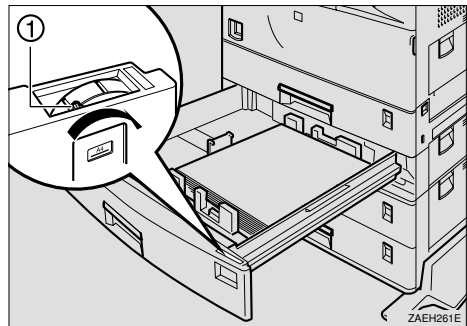

- 9** Slide the tray into the printer until it stops.

## Loading Paper in PS420 (Paper Feed Unit)

### Note

- You can load A4 long-edge feed (Metric version) or 8<sup>1</sup>/<sub>2</sub>" × 11" long-edge feed (Inch version) size into PS420. If you want to change the paper size A4 to 8<sup>1</sup>/<sub>2</sub>" × 11" (Metric version) or 8<sup>1</sup>/<sub>2</sub>" × 11" to A4 (Inch version), contact your sales or service representative.
- Load paper of the same size in the right and left sides of the paper feed unit.

- 1** Slide the paper tray out until it stops.

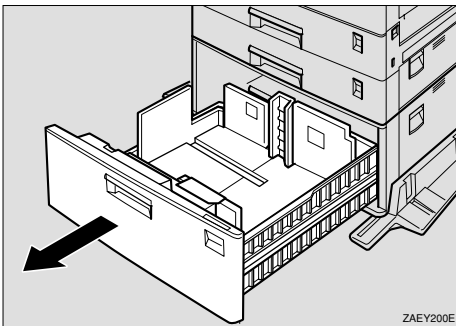

- 2** Load paper completely into the tray.

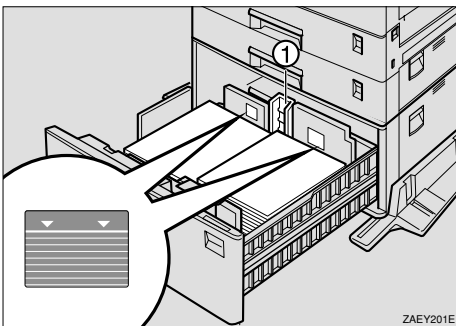

### Important

- Align the paper stack so that the left stack is flush with the left side, and the right stack is flush with the right side.
- Do not stack paper over the limit mark.
- Confirm that the end fence (①) locks completely after loading the right side paper.
- If you want to change the paper size, contact your sales or service representative.

### Note

- To avoid paper multi-feeds, shuffle sheets before setting them in the tray.
- Load the paper face up onto the tray.
- If either side or the leading edge of paper is curled, straighten it, and then load it.

- 3** Slide the tray into the printer until it stops.

## Loading Paper in Bypass Tray Type 270

### Note

- ❑ Paper sizes supported by the bypass tray are in the approximate range of 90 - 297 mm (3.54" - 11.69") in width, and 148 - 432 mm (5.83" - 17.00") in length.
- ❑ To specify a custom size with the operation panel, see "Specifying a Custom Paper Size for the Bypass Tray" in the Printer Reference included as a PDF file on the CD-ROM.
- ❑ If you load a custom or unique paper size, set the paper size using the operation panel.

### 1 Open the bypass tray.

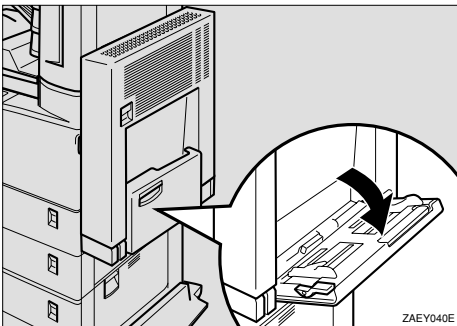

### 2 Lift the paper guide lever.

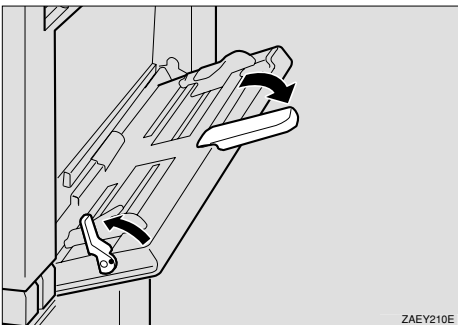

### Important

- ❑ If the paper guides do not match the paper size, skew images or paper misfeeds might occur.

### Note

- ❑ Swing out the extender to support paper sizes longer than A4 short-edge feed (Metric version) or 8 1/2" x 11" short-edge feed (Inch version).

### 3 Load the paper and adjust the paper guides to the sides of the paper.

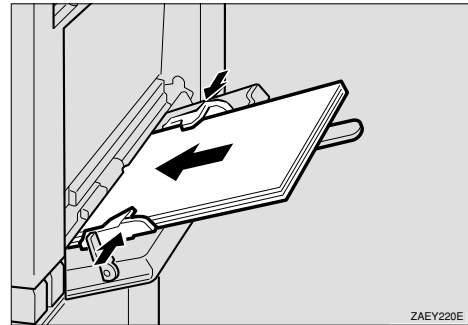

### Important

- ❑ Confirm the print side of OHP transparencies. Some OHP transparencies can be printed on only one side.

### Note

- ❑ Do not stack paper over the limit mark. If you do, skew images or paper misfeeds might occur.
- ❑ When you set a custom size or thick paper in the bypass tray, do not stack paper above the lower limit mark of the bypass tray.
- ❑ To avoid paper multi-feeds, shuffle sheets before setting them in the tray.
- ❑ Load the paper face down onto the tray.

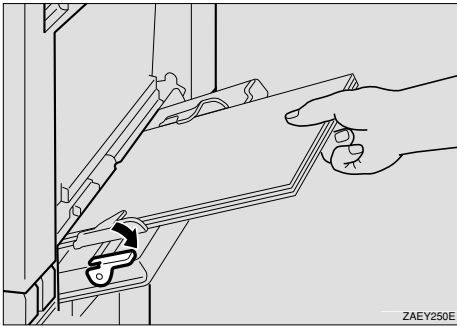
**4** Push down the paper guide lever.**Note**

- If the paper guide lever is not pushed down, paper misfeeds might occur.

**5** Turn on the printer.**Reference**

For more information about turning on the printer, see P.51 “Connecting the Power Cord”.

**6** Configure the tray for the loaded paper size and paper feed direction.**Important**

- The paper size selected with the printer driver overrides the one selected here.

**Reference**

For more information about configuring the bypass tray, see the printer driver Help.

For more information about loading custom paper, see “Loading Paper and other Media” in the Printer Reference included as a PDF file on the CD-ROM.

**1** Press **[Menu]**.

The following message appears on the panel display.

```
Main Menu:
Sample Print
```

**2** Press **[▼]** or **[▲]** until the following message appears.

```
Main Menu:
Job Control
```

**3** Press **[Enter #]**.

The following message appears on the panel display.

```
Job Control:
Paper Input
```

**4** Press **[Enter #]**.

The following message appears on the panel display.

```
Paper Input:
Tray Priority
```

**5** Press **[▼]** or **[▲]** until the following message appears.

```
Paper Input:
Bypass Size
```

**6** Press **[Enter #]**.

The following message appears on the panel display.

```
Bypass Size:
Standard Size
```

**7 Press [Enter #].**

The currently selected paper size appears on the panel display.



```
Standard Size:
*11 x 8 1/2
```

**Note**

- An asterisk ("\*") prefixes the currently selected item.

**8 Press [▼] or [▲] to select the standard size.****9 Press [Enter #].**

The following message appears on the panel display.



```
Standard Size:
*8 x 13
```

**10 After the panel display changes, press [Menu].**

The panel display returns to the ready condition as follows:



```
Ready
```

# Connecting the Power Cord

## ⚠ CAUTION:

- Do not handle the plug with wet hands. Doing this might cause an electrical shock.

## 1 Turn off the printer.

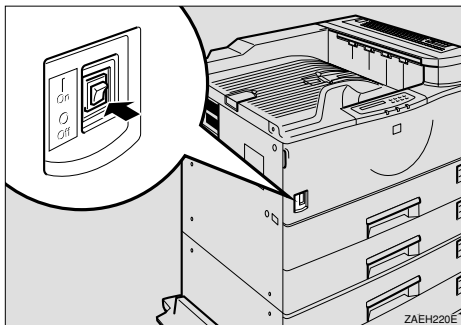

## 2 Insert the plug of the power cord securely into the printer.

## 3 Insert the plug of the power cord securely into the wall outlet.

### ⚡ Important

- Make sure that the printer is turned off before you insert or pull the plug of the power cord.

## 4 Turn on the printer.

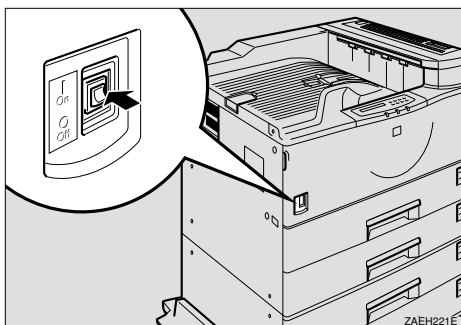

# Selecting the Panel Display Language

2

Messages on the panel display are shown in English by default. You can change the language to German, French, Italian, Dutch, Swedish, Norwegian, Danish, Spanish, Finnish, Portuguese, Czech, Polish, or Hungarian by following the steps below.

**1** Press **[Menu]**.

The following message appears on the panel display.

```
Main Menu #
Sample Print
```

**2** Press **[▼]** or **[▲]** until the following message appears.

```
Main Menu #
Language
```

**3** Press **[Enter #]**.

The following message appears on the panel display.

```
Language:
*English
```

 **Note**

An asterisk (“\*”) prefixes the currently selected item.

**4** Press **[▼]** or **[▲]** to display the language you want to select.

```
Language:
French
```

**5** Press **[Enter #]**.

The following message is displayed on the panel display for two seconds, and then the panel display automatically returns to the main menu.

```
Language:
*French
```



# Printing a Configuration Page

You can confirm the current configuration of the printer by printing a configuration page.

## Reference

For more information about the items on the configuration page, see P.54 "Interpreting a Configuration Page".

### **1** Press **[Menu]**.

The following message appears on the panel display.

```
Main Menu #
  Sample Print
```

### **2** Press **[▼]** or **[▲]** until the following message appears on the panel display.

```
Main Menu#
  List Print
```

### **3** Press **[Enter #]**.

The following message appears on the panel display.

```
List Print #
  Config. Page
```

### **4** Press **[Enter #]**.

The following message appears on the panel display.

```
Config. Page #
  Press Enter (#)
```

### **5** Press **[Enter #]**.

In a short time, printing of the configuration page will start.

## Important

- If you cannot print the configuration page correctly, check if an error message appears on the panel display. For more information about error messages, see "Error & Status Messages on the Operation Panel" in the Printer Reference included as a PDF file on the CD-ROM.

# Interpreting a Configuration Page

---

## Reference

---

- ❖ **Printer ID**  
Shows the serial number of the printer.
  - ❖ **Firmware Version**  
Shows the version number of the printer firmware.
  - ❖ **Pages Printed**  
Shows the total number of pages printed.
- 

## Memory

---

- ❖ **Total Memory**  
Shows the total amount of memory installed on the printer.
  - ❖ **Sample/Locked Print Total Memory**  
Shows the total amount of hard disk space that is available for sample print and locked print jobs.
  - ❖ **Sample/Locked Print Free Memory**  
Shows the amount of hard disk space that is available for sample print and locked print jobs.
  - ❖ **Font Download Total Memory**  
Shows the total memory used by the downloaded fonts.
  - ❖ **Font Download Free Memory**
    - **Total Memory**  
Shows the amount of memory that is available for font downloads.
    - **Free Memory**  
Shows the amount of hard disk space that is available for font downloads.
- 

## Options

---

Shows the options installed on the printer. Installed option is described as “Installed”.

---

## Job Control

---

Shows the settings made under the “Job Control” menu.

### Reference

For more information about the “Job Control” menu, see “Job Control Menu” in the Printer Reference included as a PDF file on the CD-ROM.

---

## Network Setup

---

Shows the settings made under the “Network Setup” menu and from the host computer.

### Reference

For more information about the “Network Setup” menu, see “Network Setup” in the Printer Reference included as a PDF file on the CD-ROM.

---

## Maintenance

---

Shows the settings made under the “Maintenance” menu.

### Reference

For more information about the “Maintenance” menu, see “Maintenance Menu” in the Printer Reference included as a PDF file on the CD-ROM.

---

## Language

---

Shows the currently selected language in which messages appear on the panel display.

### Reference

For more information about the “Language” menu, see “Language” in the Printer Reference included as a PDF file on the CD-ROM.

# Connecting the Printer

## Requirements

### General

Before using this printer, confirm that all the environmental and electrical requirements have been met. Connect the printer to the host computer using the parallel port, 10BASE-T/100BASE-TX port, or both.

Confirm that all the cables, connectors, and electrical outlets necessary to attach the printer to the host computer or network are present.

### Important

- The interface cable is not included in the box. It is your responsibility to provide an interface cable appropriate for the computer you are using.
- This printer comes with network-ready Ethernet capability as standard.

### Reference

For more information about using a network, see P.57 “Connecting the Printer to the Network”.

For more information about using the parallel port, see P.60 “Connecting the Printer to the Host Using a Parallel Cable”.

### Network cable

The Network Interface Board supports 10BASE-T or 100BASE-TX connections. You can use the printer in the following network environments:

- Use the appropriate network management software and printer driver.
- Attach the printer to a networked computer set up as a server.

<b>Client</b>	Windows 95/98/Me, Windows 2000 <sup>*1</sup> , Windows NT 4.0 <sup>*1</sup> , Macintosh, UNIX
<b>Driver</b>	PCL 6/5e, PostScript 3
<b>File Server</b>	NetWare 3.x, NetWare 4.x, NetWare 5 <sup>*2</sup>
<b>Protocol</b>	TCP/IP, IPX/SPX, NetBEUI <sup>*3</sup> , AppleTalk

<sup>\*1</sup> Only x86 based computers are supported.

<sup>\*2</sup> NDPS (Novell Distributed Print Services) mode is not supported.

<sup>\*3</sup> Under Windows 95/98/Me, Windows 2000 and Windows NT 4.0 only. Only for Peer-to-Peer printing.

In a mixed network environment, the protocol switches automatically.

## Reference

For more information about configuring the Network Interface Board, see the Operating Instructions for the Network Interface Board included as a PDF file on the CD-ROM.

For more information about resolving network connection problems, see "Troubleshooting" in the Printer Reference included as a PDF file on the CD-ROM.

## Note

- Consult your network administrator before connecting the printer to a network.
- In a 100BASE-TX environment, be sure to use properly shielded and grounded cable (STP, Category/Type 5) for the connection to the host computer (and/or HUB) in order to meet FCC and EMC Directive 89/336/EEC emission guidelines.

---

## Parallel cable

---

Connect the printer to the host computer parallel port. A parallel cable to connect the printer to the host computer is not included with this printer.

The printer's parallel interface is a standard bidirectional interface. It requires a standard 36-pin parallel cable compliant with IEEE 1284 and a parallel port available on the host computer.

## Note

- Do not use a parallel cable that is longer than 3 meters (10 feet).

---

## Connecting the Printer to the Network

---

Follow these steps to connect the printer to the network via its built in network interface.

- 1** Confirm that you have the correct network cable.
- 2** Turn off the printer.
- 3** Loop the network cable twice. The loops should be about 10 cm (4 inch) from the end of the cable on the end closest to the connector.

**4** Attach the ferrite core to the loops.

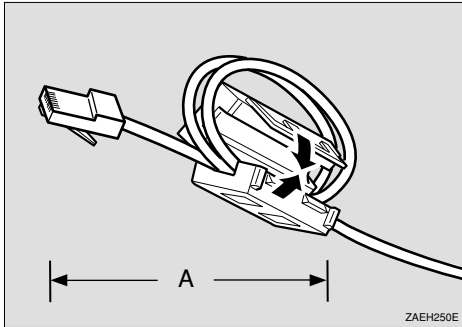

A: 10 cm (4 inch)

**5** Attach the network cable to the 10BASE-T/100BASE-TX port of the printer.

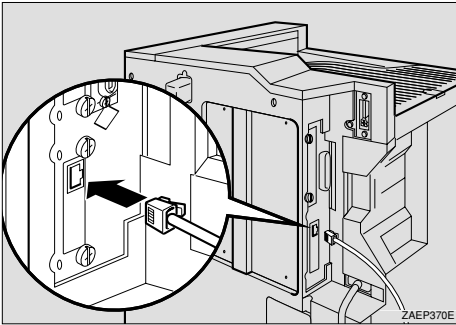

**Reference**

See P.5 “Exterior: Front View” to confirm the position of the 10BASE-T/100BASE-TX port.

**6** Connect the other end of the cable to the network.

---

## Buttons and Indicators on the Network Interface Board

---

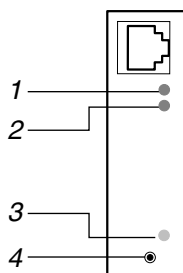

ZAEX010E

### 1. Indicator (green)

Stays on while the printer is in a network environment.

### 2. Indicator (green)

Stays on while 100BASE-TX is working.  
Stays off while 10BASE-T is working.

### 3. Indicator (orange)

Stays on while the network interface board is working.

### 4. Button

Hold down this button for more than two seconds to print the network configuration page. Hold down this button for more than five seconds to print system log information.

#### Note

- You can print the network configuration page and system log information using the “Network Status” and “Network Log” menu under the “List Print” menu on the operation panel. For more information, see P.53 “Printing a Configuration Page”.

---

## Connecting the Printer to the Host Using a Parallel Cable

---

Follow these steps to connect the printer to the host computer using a parallel cable compliant with IEEE 1284.

- 1** Confirm that you have the correct cable.
- 2** Confirm that both the printer and the host computer are turned off. If they are on, turn them off.
- 3** Plug the 36-pin end of the parallel cable into the parallel port of the printer.

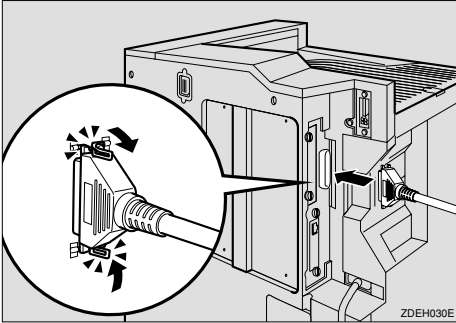

 **Reference**

See P.5 “Exterior: Front View” to confirm the position of the parallel port.

- 4** Squeeze the wire clips on each side of the connector together until they snap into place. The clips hold the cable securely in place.
- 5** Plug the other end of the parallel cable into the computer's parallel port.



# 3. Configuring the Printer for the Network

## Configuring the Printer for the Network with the Operation Panel

### Reference

This printer contains a Network Interface Board as a standard. For more information about configuring for a network, see the Operating Instructions for the Network Interface Board included as a PDF file on the CD-ROM.

To use the Network Interface Board, configure it for the network using the printer's operation panel.

The following table shows the operation panel settings and their defaults. These are included in the "Network Setup" menu.

Setting name	Default value
IP Address	011.022.033.044
Subnet Mask	000.000.000.000
Gateway Address	000.000.000.000
Access Control (Access Control Address)	000.000.000.000
Access Mask (Access Control Mask)	000.000.000.000
Network Boot	None
Frame Type(NW) (Frame Type NetWare)	Auto Select
ActiveProtocols	All Active
Ethernet	Auto Select

### **1** Press **[Menu]**.

The following message appears on the panel display.

```
Main Menu #
Sample Print
```

### **2** Press **[▼]** or **[▲]** until the following message appears.

```
Main Menu #
Network Setup
```

### **3** Press **[Enter #]**.

The following message appears on the panel display.

```
Network Setup #
IP Address
```

**4** Referring to the following table, select the menu item appropriate to the network.

Menu item on the panel display	Active Protocol			
	TCP <sup>*1</sup>	NW <sup>*2</sup>	AT <sup>*3</sup>	NB <sup>*4</sup>
All Active (Default Setting)	✓	✓	✓	✓
None				
TCP/IP Only	✓			
NetWare Only		✓		
TCP/IP & NetW	✓	✓		
ATalk Only			✓	
TCP/IP & ATalk	✓		✓	
NetWare & ATalk		✓	✓	
TCP & NW & ATK	✓	✓	✓	
NetBEUI only				✓
TCP/IP & NB	✓			✓
NetBEUI & NetW		✓		✓
TCP & NB & NW	✓	✓		✓
NetBEUI & ATalk			✓	✓
TCP & NB & ATK	✓		✓	✓
NB & NW & ATalk		✓	✓	✓

- ✓ means that this protocol is active.
- A blank cell means this protocol is not active.

<sup>\*1</sup> TCP/IP  
<sup>\*2</sup> NetWare  
<sup>\*3</sup> AppleTalk  
<sup>\*4</sup> NetBEUI

**Note**

- ❑ Do not select protocols that are not used on the network.
- ❑ When using Pure IP under NetWare 5, select TCP/IP to be active.

**1** Press [▼] or [▲] until the following message appears.

Network Setup ⌘  
 ActiveProtocols

**2** Press [Enter #].

The following message appears on the panel display.

ActiveProtocols ⌘  
 ⌘All Active

**Note**

- ❑ An asterisk (“\*”) prefixes the currently selected item.

**3** Press [▼] or [▲] until the protocol you want to use appears.

**4** Press [Enter #].

The actual procedure may differ depending on the protocol you use. Follow the appropriate steps below.

TCP/IP	5 ▶ 6 ▶ 7 ▶ 8 ▶ 0
NetWare	9 ▶ 0
Apple-Talk	0
NetBEUI	0

**5** If you use TCP/IP, you should assign an IP address to the printer.

**Note**

- ❑ To obtain an IP address for the printer, contact your network administrator.
- ❑ The IP address is shown in dotted decimal format on the panel display.

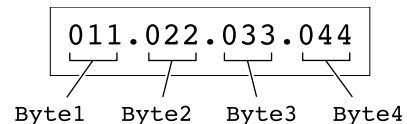

**1** Press [▼] or [▲] until the following message appears.

Network Setup ⌘  
 IP Address

**2** Press **[Enter #]**.

Byte 1 of the IP address appears on the panel display.

IP Address # Byte 1 = 11
-----------------------------

**3** Use **[▲]** or **[▼]** to edit the value.

**4** Press **[Enter #]**.

Byte 2 of the IP address appears.

IP Address # Byte 2 = 22
-----------------------------

**5** Use **[▲]** or **[▼]** to edit the value.

Repeat steps **3** and **4** to specify the remaining bytes.

**6** Press **[Enter #]** to register the IP address you specified.

**6** If you use TCP/IP, you should assign the "Subnet Mask" and "Gateway Address" using the same procedure for specifying the IP address.

**7** If you use TCP/IP, set the "Access Control" and "Access Mask" using the same procedure for specifying the IP address, if necessary.

**8** If you use TCP/IP, you can make settings for "Network Boot".

Choose how to obtain the printer's IP address from a server on the network. The following methods are available.

Menu item on the panel display	Available methods			
	AR <sup>*1</sup>	RA <sup>*2</sup>	BO <sup>*3</sup>	DH <sup>*4</sup>
ARP + PING	✓			
ARP & RARP	✓	✓		
ARP & BOOTP	✓		✓	
ARP&RARP&BOOTP	✓	✓	✓	
None (Default Setting)				
RARP + TFTP		✓		
BOOTP			✓	
RARP & BOOTP		✓	✓	
DHCP				✓

\*1 ARP + PING

\*2 RARP + TFTP

\*3 BOOTP

\*4 DHCP

**Note**

You must have configured the server in order to use "RARP + TFTP", "BOOTP", or "DHCP".

**1** Press **[▼]** or **[▲]** until the following message appears.

Network Setup # Network Boot
---------------------------------

**2** Press **[Enter #]**.

The current setting appears on the panel display.

Network Boot # #None
-------------------------

**3** Use **[▼]** or **[▲]** until the method you want to use appears.

**4** Press **[Enter #]**.

**9** If you use NetWare, select the NetWare frame type.

Select one of the items below if necessary.

- Auto Select (Default)
- Ethernet 802.3
- Ethernet 802.2
- Ethernet II
- Ethernet SNAP

**Note**

In most situations, use the default setting ("Auto Select"). When you select "Auto Select", the frame type first detected by the printer is adopted. If the network can use more than two frame types, the printer may fail to select the correct frame type if "Auto Select" is selected. In this case, select the appropriate frame type.

**1** Press **[▼]** or **[▲]** until the following message appears.

```
Network Setup #
Frame Type(NW)
```

**2** Press **[Enter #]**.

The current setting appears on the panel display.

```
Network Setup #
*Auto Select
```

**3** Use **[▼]** or **[▲]** until the frame type you want to use appears.

**4** Press **[Enter #]**.

**10** Exit the setup menu to the available function settings.

**1** Press **[Escape]**.

**2** Press **[Escape]**.

**11** If you want to confirm the printer's configuration, print a configuration page.

**1** Press **[Menu]**.

The following message appears on the panel display.

```
Main Menu #
Sample Print
```

**2** Press **[▼]** or **[▲]** until the following message appears.

```
Main Menu #
List Print
```

**3** Press **[Enter #]**.

The following message appears on the panel display.

```
List Print #
Config. Page
```

**4** Press **[Enter #]**.

The following message appears on the panel display.

```
Config. Page #
Press Enter (#)
```

When printing a configuration page, you can confirm the printer's configuration.

 **Address**
**❖ Subnet Mask**

A number used to mathematically "mask" or hide an IP Address on the network by eliminating those parts of the address that are alike for all the printers on the network.

**❖ Gateway Address**

A gateway is a connection or interchange point that connects two networks. A gateway address is for the router or host computer used as a gateway.

 **Note**

- To obtain the above addresses, contact your network administrator.

**❖ Access Control Address and Access Control Mask**

The Access Control Address and Access Control Mask are used in combination with the client's IP Addresses that have access to the computer used for printing. If it is not necessary for you to control the access rights, select "0.0.0.0".

 **Note**

- When the Access Control Address settings coincide with the masked result of the IP Address of the computer, print jobs from that IP Address can be accepted by the network interface board.
- For example, if you assign 192.168.15.16 as the Access Control Address to the network interface board, the combination of the Access Control Mask and IP Address that can have access are as follows. (xxx: for any numerical value)

Access Control Mask	IP Addresses that have access
0. 0. 0. 0	XXX.XXX.XXX.XXX
255. 0. 0. 0	192.XXX.XXX.XXX
255.255. 0. 0	192.168.XXX.XXX
255.255.255. 0	192.168. 15.XXX
255.255.255.255	192.168. 15. 16

3

# 4. Installing the Printer Driver and Software

This manual assumes that you are familiar with general Windows procedures and practices. If you are not, see the documentation that comes with Windows for details.

## Installation Method

The following table shows how to install the printer drivers and software.

	Auto Run <sup>*1</sup>			Add Printer Wizard
	Typical <sup>*2</sup>	Network <sup>*3</sup>	Custom <sup>*4</sup>	
PCL 6 printer driver	<input type="radio"/>	<input type="radio"/>	<input type="radio"/>	
PCL 5e printer driver			<input type="radio"/>	
PostScript printer driver				<input type="radio"/>
Agfa Font Manager			<input type="radio"/>	
PRINTER MANAGER FOR ADMINISTRATOR			<input type="radio"/>	
PRINTER MANAGER FOR CLIENT		<input type="radio"/>	<input type="radio"/>	
PortNavi		<input type="radio"/>	<input type="radio"/>	
Multidirect Print			<input type="radio"/>	
Acrobat Reader			<input type="radio"/>	

<sup>\*1</sup> Available operating systems are as follows: Windows 95/98/Me, Windows 2000, Windows NT 4.0

<sup>\*2</sup> Recommended for most users.

<sup>\*3</sup> Recommended for network printing users.

<sup>\*4</sup> Recommended for expert users.

### Reference

For more information about the printer drivers, see P.3 “Printer Drivers for This Printer”. For installing the printer drivers, see P.70 “Installing the PCL 6/5e Printer Driver” or P.72 “Installing the PostScript Printer Driver”.

For more information about the software and utilities, see P.4 “Software and Utilities Included on the CD-ROM”.

### Important

- Before starting this installation, close all documents and applications. In a network environment, confirm that users who are logged on are disconnected. Be sure to do this when it will create the least interference with other users.
- After installing a printer driver, you must restart the computer.

 **Note**

- ❑ If the "plug and play" function is started, click **[Cancel]** in the **[New Hardware Found]**, **[Device Driver Wizard]** or **[Found New Hardware Wizard]** dialog box, and then insert the CD-ROM. The **[New Hardware Found]**, **[Device Driver Wizard]** or **[Found New Hardware Wizard]** dialog box appears depending on the system version of the Windows 95/98/Me or Windows 2000.
- ❑ The appropriate language name is used for the CD-ROM folder: ENGLISH (English), DEUTSCH (German), FRANCAIS (French), ITALIANO (Italian), ESPANOL (Spanish), NEDRLNDS (Dutch), NORSK (Norwegian), DANSK (Danish), SVENSKA (Swedish), POLSKI (Polish), PORTUGUS (Portuguese), SUOMI (Finnish), MAGYAR (Hungarian), CESKY (Czech)

❖ **User Codes**

User Codes are eight digit numbers that allow you to keep track of printing done under each code. You can confirm the track with the PRINTER MANAGER FOR ADMINISTRATOR.

 **Reference**

For the name of the PRINTER MANAGER FOR ADMINISTRATOR application you have, see the inside of front cover of this manual.

For more information, see the Help file.



# Installing by Auto Run

You can install the PCL printer driver and software, and set them up easily by using Auto Run.

Follow these steps to install the PCL printer driver and software on Windows 95/98/Me, Windows 2000, Windows NT 4.0.

## Limitation

- If your system is Windows 2000 or Windows NT 4.0, installing a printer driver by Auto Run requires Administrators permission. When you install a printer driver by Auto Run, log on using an account that has Administrators permission.

## Note

- Auto Run might not automatically work with certain OS settings. In this case, launch "INSTTOOL.EXE" located on the CD-ROM root directory.
- If you want to cancel Auto Run, hold down the **[SHIFT]** key (when your system is Windows 2000, hold down the left **[SHIFT]** key) while inserting the CD-ROM. Keep the **[SHIFT]** key held down until the computer has finished accessing the CD-ROM.

- 1** Close all applications that are running.
- 2** Insert the CD-ROM into the CD-ROM drive.
- 3** Follow the instructions on the screen.
- 4** Restart the computer after installation is complete.
- 5** Set up the options with the printer driver.

# Installing the PCL 6/5e Printer Driver

---

## Windows 95/98/Me - Installing the PCL 6/5e Printer Driver

---

### Installing the printer driver

---

Install the driver in accordance with the steps explained. ⇒ P.69 “*Installing by Auto Run*”

---

### Setting up options

---

4

#### **Note**

- When setting up options, you should access the Printer Properties from Windows. You cannot access the Printer Properties from an application.

**1** Click **[Start]** on the taskbar, point to **[Settings]**, and then click **[Printers]**.

The **[Printers]** window appears.

**2** Click the icon of the printer you want to use. On the **[File]** menu, click **[Properties]**.

**3** Click the **[Accessories]** tab.

**4** Select any options you have installed from the **[Options]** group.

**5** Click **[OK]**.

---

## Windows 2000 - Installing the PCL 6/5e Printer Driver

---

### Installing the printer driver

---

Install the driver in accordance with the steps explained. ⇒ P.69 “*Installing by Auto Run*”

---

#### **Note**

- During installation, the **[Digital Signature Not Found]** dialog box might appear. In this case, click **[Yes]** to continue the installation.
- 

### Setting up options

---

#### **Note**

- When setting up options, you should access the Printer Properties from Windows. You cannot access the Printer Properties from an application.

- 1** Click **[Start]** on the taskbar, point to **[Settings]**, and then click **[Printers]**.  
The **[Printers]** window appears.
- 2** Click the icon of the printer you want to use. On the **[File]** menu, click **[Properties]**.
- 3** Click the **[Accessories]** tab.
- 4** Select any options you have installed from the **[Options]** group.
- 5** Click **[OK]** .

---

## Windows NT 4.0 - Installing the PCL 6/5e Printer Driver

---

---

### Installing the printer driver

---

Install the driver in accordance with the steps explained. ⇒ P.69 *“Installing by Auto Run”*

---

### Setting up options

---

 **Note**

- When setting up options, you should access the Printer Properties from Windows. You cannot access the Printer Properties from an application.

- 1** Click **[Start]** on the taskbar, point to **[Settings]**, and then click **[Printers]**.  
The **[Printers]** window appears.
- 2** Click the icon of the printer you want to use. On the **[File]** menu, click **[Properties]**.
- 3** Click the **[Accessories]** tab.
- 4** Select any options you have installed from the **[Options]** group.
- 5** Click **[OK]** .

# Installing the PostScript Printer Driver

---

## Windows 95/98/Me - Installing the PostScript Printer Driver

---

### Important

- Be sure to install the PPD file for Windows 95/98/Me. Do not accidentally install the PPD file for Windows 2000 or Windows NT 4.0.

---

### Installing the printer driver

---

- 1** Close all applications that are running.
- 2** Click **[Start]** on the taskbar, point to **[Settings]**, and then click **[Printers]**.  
The **[Printers]** window appears.
- 3** Double-click the **[Add Printer]** icon.  
**[Add Printer Wizard]** starts.
- 4** Click **[Next]**.
- 5** Click **[Local printer]**, and then click **[Next]**.  
A dialog box for selecting the printer manufacturer and model name appears.
- 6** Click **[Have Disk]**.  
A dialog box for installing a driver from a disk appears.
- 7** Hold down the **[SHIFT]** key while inserting the CD-ROM. Keep the **[SHIFT]** key held down until the computer has finished accessing the CD-ROM.  
 **Note**  
 If the Auto Run program starts, click **[Cancel]**.
- 8** Click **[Browse]**.
- 9** Use the **[Drives:]** list box to select the CD-ROM drive.
- 10** In the box, double-click **[DRIVERS]**, **[PS]** and **[WIN95\_98]**. Then double-click the folder of the appropriate language, and double-click **[DISK1]**. Finally, click **[OK]**.
- 11** Click **[OK]**.  
A dialog box for selecting the printer model appears.
- 12** Click the name of the printer you want to install, and then click **[Next]**.  
A dialog box for selecting the printer port appears.

- 13** From the **[Available ports:]** box, select the printer port, and then click **[Next]**.
- 14** Change the name of the printer if you want, and then click **[Next]**.
- 15** In the next dialog box asking if you want to print a test page, select **[No]** and then click **[Finish]**.

The installer copies the printer driver files from the CD-ROM to the computer's hard disk.

 **Note**

  - Print a test page after completing installation and restarting Windows.
- 16** Restart the computer after installation is complete.
- 17** Set up the options with the printer driver.

---

### Setting up options

---

-  **Note**
- When setting up options, you should access the Printer Properties from Windows. You cannot set up options when accessing the Printer Properties from an application.
- 1** Click **[Start]** on the taskbar, point to **[Settings]**, and then click **[Printers]**.

The **[Printers]** window appears.
  - 2** Click the icon of the printer you want to use. On the **[File]** menu, click **[Properties]**.
  - 3** Click the **[Device Options]** tab.

The **[Installable options]** group appears.
  - 4** From the **[Installable options]** box, select the option you have installed.

The current setting is displayed in the **[Change settings for:]** list.
  - 5** Use the **[Change setting for:]** list to select the appropriate setting for the selected option.
  - 6** Click **[Apply]** to apply the settings you made.
  - 7** After making all settings you want, click **[OK]**.

---

## Windows 2000 - Installing the PostScript Printer Driver

---

### Limitation

- Installing a printer driver requires Manage Printers permission. Members of the Administrators, and Power Users groups have Manage Printers permission by default. When you install a printer driver, log on using an account that has Manage Printers permission.

### Important

- Be sure to install the PPD file for Windows 2000. Do not accidentally install the PPD file for Windows 95/98/Me or Windows NT 4.0.

---

### Installing the printer driver

---

**1** Close all applications that are running.

**2** Click **[Start]** on the taskbar, point to **[Settings]**, and then click **[Printers]**.

The **[Printers]** window appears.

**3** Double-click the **[Add Printer]** icon.

**[Add Printer Wizard]** starts.

**4** Click **[Next]**.

**5** Click **[Local printer]**, clear the **[Automatically detect and install my Plug and Play printer]** check box, and then click **[Next]**.

A dialog box for selecting the printer port appears.

**6** Click the port you want to use, and then click **[Next]**.

A dialog box for selecting the printer manufacturer and model name appears.

**7** Click **[Have Disk]**.

A dialog box for installing a driver from a disk appears.

**8** Hold down the left **[SHIFT]** key while inserting the CD-ROM. Keep the left **[SHIFT]** key held down until the computer has finished accessing the CD-ROM.

#### Note

- If the Auto Run program starts, click **[Cancel]**.

**9** Click **[Browse]**.

**10** In the **[Look in:]** box, click the CD-ROM drive.

**11** In the box, double-click **[DRIVERS]**, **[PS]** and **[WIN2000]**. Then double-click the folder of the appropriate language for the operating system, and double-click **[DISK1]**. Finally, click **[Open]**.

**12** Click **[OK]**.

A dialog box for selecting the printer model appears.

**13** Click the name of the printer you want to install, and then click **[Next]**.

A dialog box for changing the printer name appears.

**14** Change the name of the printer if you want, and then click **[Next]**.

**15** Click **[Next]**.

**16** In the next dialog box asking if you want to print a test page, select **[No]** and then click **[Next]**.

A confirmation dialog box appears.

 **Note**

Print a test page after completing installation and restarting Windows.

**17** Confirm the settings you have set, and then click **[Finish]**.

The installer copies the printer driver files from the CD-ROM to the computer's hard disk.

 **Note**

If the **[Digital Signature Not Found]** dialog box appears, click **[Yes]** to continue the installation.

**18** Restart the computer after installation is complete.

**19** Set up the options with the printer driver.

---

## Setting up options

---

 **Limitation**

Changing the printer settings requires Manage Printers permission. Members of the Administrators and Power Users groups have Manage Printers permission by default. When you set up options, log on using an account that has Manage Printers permission.

 **Note**

When setting up options, you should access the Printer Properties from Windows. You cannot set up options when accessing the Printer Properties from an application.

**1** Click **[Start]** on the taskbar, point to **[Settings]**, and then click **[Printers]**.

The **[Printers]** window appears.

- 2** Click the icon of the printer you want to use. On the [File] menu, click [Properties].
- 3** Click the [Device Settings] tab.
- 4** From the [Installable Options] list, select the options you have installed.
- 5** Click [Apply] to apply the settings you made.
- 6** After making all settings you want, click [OK].

---

## Windows NT 4.0 - Installing the PostScript Printer Driver

---

### Limitation

- Installing a printer driver requires Full Control access permission. Members of the Administrators, Server Operators, Print Operators, and Power Users groups have Full Control permission by default. When you set up options, log on under Full Control permission.

### Important

- Be sure to install the PPD file for Windows NT 4.0. Do not accidentally install the PPD file for Windows 95/98/Me or Windows 2000.

---

### Installing the printer driver

---

- 1** Close all applications that are running.
- 2** Click [Start] on the taskbar, point to [Settings], and then click [Printers].  
The [Printers] window appears.
- 3** Double-click the [Add Printer] icon.  
[Add Printer Wizard] starts.
- 4** After confirming that the [My Computer] option is selected, click [Next].  
A dialog box for selecting the printer port appears.
- 5** Click the check box of the printer port you want to use, and then click [Next].  
A dialog box for selecting the printer manufacturer and model name appears.
- 6** Click [Have Disk].  
A dialog box for installing a driver from a disk appears.
- 7** Hold down the [SHIFT] key while inserting the CD-ROM. Keep the [SHIFT] key held down until the computer has finished accessing the CD-ROM.

### Note

- If the Auto Run program starts, click [Cancel].



- 8** Change the drive name in the list box to the name of the CD-ROM drive, and then click **[Browse]**.
- 9** In the box, double-click **[DRIVERS]**, **[PS]** and **[NT4]**. Then double-click the folder of the appropriate language for the operating system, and double-click **[DISK1]**. Finally, click **[Open]**.
- 10** Click **[OK]**.

A printer model selection dialog box appears.
- 11** Click the name of the printer you want to install, and then click **[Next]**.

A dialog box for changing the printer name appears.
- 12** Change the name of the printer if you want, and then click **[Next]**.
- 13** Click **[Next]**.
- 14** In the next dialog box asking if you want to print a test page, select **[No]** and then click **[Finish]**.

The installer copies the printer driver files from the CD-ROM to the computer's hard disk.

 **Note**

  - Print a test page after completing installation and restarting Windows.
- 15** Restart the computer after installation is complete.
- 16** Set up the options with the printer driver.

---

## Setting up options

---

### **Limitation**

- Changing the printer settings requires Full Control access permission. Members of the Administrators, Server Operators, Print Operators, and Power Users groups have Full Control permission by default. When you set up options, log on under Full Control permission.

### **Note**

- When setting up options, you should access the Printer Properties from Windows. You cannot set up options when accessing the Printer Properties from an application.

- 1** Click **[Start]** on the taskbar, point to **[Settings]**, and then click **[Printers]**.

The **[Printers]** window appears.
- 2** Click the icon of the printer you want to use. On the **[File]** menu, click **[Properties]**.

- 3** Click the **[Device Settings]** tab.
- 4** Select any options you have installed from **[Installable Options]** group.
- 5** Click **[OK]**.

# Using Adobe PageMaker Version 6.0 or 6.5

If you use the printer under Windows 95/98/Me/Windows 2000/Windows NT 4.0 with Adobe PageMaker, you need to copy the PPD file to the PageMaker folder.

The PPD file is the file with extension ".ppd". It is in the folder "\PS\WIN95\_98\Language\DISK1\" on the CD-ROM.

The **[WIN95\_98]** folder, inside the **[PS]** folder is for the Windows 95/98/Me operating system. Use the folder at this level that is appropriate for the operating system you are using.

The third folder, "(Language)" may be substituted by an appropriate language name.

## Reference

For more information about the language name, see P.67 "*Installation Method*".

Copy this file to the PageMaker folder.

For the PageMaker 6.0 default installation, the folder is "C:\PM6\RSRC\PPD4", and for the PageMaker 6.5 default installation, the directory is "C:\PM65\RSRC\USENGLISH\PPD4". The "USENGLISH" folder may be different, depending on your language selection.

# Macintosh

---

## Macintosh - Installing the PostScript Printer Driver

---

It is necessary to install a printer driver and a PPD file to print from a Macintosh. Follow these steps to install a printer driver and a PPD file into a Macintosh using a system 7.6.1 ~ 9.0 operating system.

- 1** Insert the CD-ROM into the CD-ROM drive.
- 2** Double-click the CD-ROM icon.
- 3** Double-click the [PS DRIVER] folder.
- 4** Double-click the folder of the language you use.
- 5** Open [DISK1] and double-click the installer icon.
- 6** Follow the instructions on the screen.
- 7** Double-click [Extensions].
- 8** Double-click [Printer Descriptions].
- 9** Double-click the CD-ROM icon on the desktop.
- 10** Double-click the [PRINTER DESCRIPTIONS] folder.
- 11** Double-click the folder of the language you use.
- 12** Double-click [DISK1].
- 13** Select all files in [DISK1] and drag them into [Printer Descriptions] in [Extensions] in [System Folder].
- 14** Restart the Macintosh.

---

## Setting Up the PPD File

---

### Preparation

Confirm that the printer is connected to an AppleTalk network before performing the following procedure.

- 1** On the [Apple] menu, click [Chooser].
- 2** Click the [Adobe PS] icon.
- 3** In the [Select a PostScript Printer:] list, click the name of the printer you want to use.
- 4** Click [Create].
- 5** Click the printer you want to use, and then click [Select].

The PPD file is set up, and the [Adobe PS] icon appears at the left of the printer name in the list. Next, use the procedure on P.81 “Setting Up Options” to make the option settings, or close the [Chooser] dialog box.

---

## Setting Up Options

---

- 1** On the [Apple] menu, select [Chooser].
- 2** Click the [Adobe PS] icon.
- 3** In the [Select the PostScript Printer:] list, click the name of the printer you want to use, and then click [Setup].
- 4** Click [Configure].  
A list of options appears.
- 5** Select the option you want to set up and select the appropriate setting for it.

### Note

- If the option you want to set up is not displayed, the PPD file might not be set up correctly. Check the name of the PPD file shown in the dialog box.

- 6** Click [OK].  
The list of options closes.
- 7** Click [OK].  
The [Chooser] dialog box appears.
- 8** Close the [Chooser] dialog box.

# INDEX

## A

---

Access Control Address, 61, 65  
Access Control Mask, 61, 65  
ActiveProtocols, 61  
AD380, 26  
Agfa Font Manager, 4  
Auto Run, 69

## B

---

Bridge Unit Type 320, 33  
Bypass Tray Type 270, 30, 48

## C

---

Caution, ii  
configuration page, 53, 54  
CS370, 37

## D

---

Data In indicator, 8

## E

---

Energy Star, v  
Enter # key, 9  
Error indicator, 8  
Escape key, 9

## F

---

Firmware Version, 54  
Font Download Free Memory, 54  
Font Download Total Memory, 54  
Form Feed key, 9  
Frame Type NetWare, 61  
front cover, 5  
fusing unit, 7

## G

---

Gateway Address, 61, 65

## I

---

Interchange Unit Type 280, 24  
IP Address, 61

## J

---

Job Control, 55  
Job Reset key, 9

## L

---

Language, 55  
lower right cover 1, 6  
lower right cover 2, 6

## M

---

Macintosh  
    *install, PPD, 80*  
    *setting up options, 81*  
Maintenance, 55  
Memory, 54  
Memory Unit TypeB, 39  
Menu key, 9  
Multidirect Print, 4

## N

---

Network Boot, 61  
Network Interface Board  
    Operating Instructions, vi  
network interface port, 5  
Network Setup, 55

## O

---

On Line indicator, 8  
On Line key, 9  
operation panel, 5  
Options, 16, 54  
options, setting up  
    *Macintosh, 81*  
output tray, 5

## P

---

PageMaker 6.0 or 6.5, 79  
Pages Printed, 54  
panel display, 8  
paper feed unit, 5  
paper tray, 5  
parallel cable, 57, 60  
parallel interface port, 5  
PCL 5e, 3  
    *Windows 2000, install*, 70  
    *Windows 95/98/Me, install*, 70  
    *Windows NT 4.0, install*, 71  
PCL 6, 3  
    *Windows 2000, install*, 70  
    *Windows 95/98/Me, install*, 70  
    *Windows NT 4.0, install*, 71  
photoconductor unit, 7  
PortNavi, 4  
PostScript, 3  
    *Macintosh, install*, 80  
    *Windows 2000, install*, 74  
    *Windows 95/98/Me, install*, 72  
    *Windows NT 4.0, install*, 76  
PostScript 3  
    Operating Instructions Supplement, vi  
power cord, 6  
Power indicator, 8  
power switch, 5  
PPD, 3, 81  
printer board cover, 6  
printer driver, 70, 71, 76, 3  
Printer Hard Disk Type 185, 40  
Printer ID, 54  
PRINTER MANAGER FOR  
    ADMINISTRATOR, 4  
PRINTER MANAGER FOR CLIENT, 4  
Printer Reference, vi  
PS420, 20, 47  
PS440, 5, 20

## R

---

Reference, 54  
right cover, 6, 7

## S

---

Safety Information, ii  
Sample/Locked Print Free Memory, 54  
Sample/Locked Print Total Memory, 54  
Setup Guide, vi  
SR510, 35  
Subnet Mask, 61, 65

## T

---

toner bottle, 42  
toner holder, 7  
toner lock lever, 7  
Total Memory, 54  
transfer unit, 7

## U

---

UNIX Supplement, vi  
upper right cover, 5  
User Code, 68

## V

---

ventilator, 5

## W

---

Warning, ii  
Windows 2000  
    *install, PCL 6/5e*, 70  
    *install, PostScript*, 74  
Windows 95/98/Me  
    *install, PCL 6/5e*, 70  
    *install, PostScript*, 72  
Windows NT 4.0  
    *install, PCL 6/5e*, 71  
    *install, PostScript*, 76







Declaration of Conformity

“The Product complies with the requirements of the EMC Directive 89/336/EEC and the Low Voltage Directive 73/23/EEC.”

**Caution (in case of 100BaseTX environment):**

1. Properly shielded and grounded cables (STP) and connectors must be used for connections to host computer (and/or peripheral) in order to meet EMC Directive 89/336/EEC emission limits.
2. STP with ferrite core must be used for RF interference suppression.

In accordance with IEC 60417, this machine uses the following symbols for the main power switch:

**I means POWER ON.**

**O means POWER OFF.**



## RICOH COMPANY, LTD.

15-5, Minami Aoyama 1-chome,  
Minato-ku, Tokyo 107-8544, Japan  
Phone: +81-(0)3-3479-3111

## Overseas Affiliates

### U.S.A.

RICOH CORPORATION  
5 Dedrick Place  
West Caldwell, New Jersey 07006  
Phone: +1-973-882-2000

### The Netherlands

RICOH EUROPE B.V.  
Groenelaan 3, 1186 AA, Amstelveen  
Phone: +31-(0)20-5474111

### United Kingdom

RICOH UK LTD.  
RicoH House,  
1 Plane Tree Crescent, Feltham,  
Middlesex, TW13 7HG  
Phone: +44-(0)20-8261-4000

### Germany

RICOH DEUTSCHLAND GmbH  
Mergenthalerallee 38-40,  
65760 Eschborn  
Phone: +49-(0)6196-9060

### France

RICOH FRANCE S.A.  
383, Avenue du Général de Gaulle  
BP 307-92143 Clamart Cedex  
Phone: +33-(0)1-40-94-38-38

### Spain

RICOH ESPAÑA S.A.  
Avda. Litoral Mar, 12-14,  
08005 Barcelona  
Phone: +34-(0)93-295-7600

### Italy

RICOH ITALIA SpA  
Via della Metallurgia 12,  
37139 Verona  
Phone: +39-045-8181500

### Hong Kong

RICOH HONG KONG LTD.  
21/F., Tai Yau Building,  
181, Johnston Road,  
Wan Chai, Hong Kong  
Phone: +852-2862-2888

### Singapore

RICOH ASIA PACIFIC PTE.LTD.  
260 Orchard Road,  
#15-01/02 The Heeren,  
Singapore 238855  
Phone: +65-830-5888

Model number: RICOH Aficio AP3200

EE (GB) G062-8680